

JRG

**Montage- und Bedienungsanleitung
Notice de montage et d'utilisation
Istruzioni di montaggio e d'uso
Installation and operation instructions**



JRGUMAT®

**Thermomischer
Mitigeurs**

Termomiscelatore

Thermoblending valve

JRG 3400/3410

Montage- und Bedienungsanleitung

Bitte lesen Sie die vorliegende Montage- und Bedienungsanleitung aufmerksam durch. Die eingesetzten Symbole bedeuten:



Gefahr

Dieses Symbol weist auf ein hohes Verletzungsrisiko für Personen hin. Die Sicherheitshinweise müssen beachtet werden.



Warnung

Dieses Symbol weist auf eine Information hin, deren Nichtbeachtung zu umfangreichen Sachschäden führen kann. Die Sicherheitshinweise sind zu beachten.



Hinweis

Dieses Symbol weist auf eine Information hin, die wichtige Angaben hinsichtlich der Verwendung enthält. Das Nichtbefolgen kann zu Störungen führen.

Die Montage- und Bedienungsanleitung ist bei der Anlagenübergabe der Bauherrschaft zu übergeben.

Technische Änderungen bleiben jederzeit vorbehalten.

Einsatzbereich/Funktion

Die tausendfach bewährten JRGUMAT[®] Thermomischer sind thermostatisch regelnde Mischventile, die überall dort eingesetzt werden, wo eine konstante Mischwassertemperatur von hoher Regelgenauigkeit gewünscht und verlangt wird.

Zum Beispiel als Zentralmischer in Ein- und Mehrfamilienhäusern, Spitälern, Alters- und Pflegeheimen, Hotels, Kasernen, Duschanlagen von Sportstätten, Industrie- und Gewerbebauten.

JRGUMAT[®] Thermomischer dienen auch als Über-temperaturschutz in Alternativenergie-Anlagen, wie Solar-Anlagen, Stückholzheizungen, Holzschnitzelfeuerungen, Pelletöfen, etc. Dank der hohen Regelgenauigkeit werden JRGUMAT[®] Thermomischer auch für Spezialanwendungen, wie z.B. Temperaturhochhaltung als Regulierorgane eingesetzt.



Der JRGUMAT[®] Thermomischer ist ein proportional regelnder Dreiwegmischer in offener Architektur. Funktionen wie Rückflussverhinderung, Absperrung oder die Regulierung des Zirkulationsvolumenstroms können nicht durch den JRGUMAT[®] Thermomischer übernommen werden. Es sind entsprechende Armaturen gemäss den Einbauschemen einzubauen.



Einbauvorschriften

Der JRGUMAT[®] Thermomischer funktioniert in jeder Einbaulage. Es sind die Einbauvorschriften über den Wassererwärmer-Kreislauf, sowie die örtlichen Normen einzuhalten. Es dürfen nur die in den Schemas vorgeschriebenen Rückflussverhinderer eingebaut werden. Als Absperrventile dürfen nur druckverlustarme Ventile, wie Schrägsitzventile, Schieber und Kugelhahnen installiert werden. Vor dem Einbau des JRGUMAT[®] Thermomischer sind die Leitungen gründlich zu spülen. Um ein Fehlverhalten des Mischers durch Strahlungswärme zu verhindern, sollte der Mischer seitlich des Erwärmers positioniert und ein Mindestabstand von einem Meter zwischen Wassererwärmer und JRGUMAT[®] eingehalten werden. Kann ein Mindestabstand nicht eingehalten werden, muss ein Thermosifon installiert werden.



Rückflussverhinderung

Für den Anschluss der JRGUMAT[®] Thermomischer dürfen nur druckverlustarme Rückschlagventile JRG 1611-1615, Rückschlagklappen JRG 1682 und Rückflussverhinderer absperrbar JRG 5262-5281 verwendet werden.



Lötverschraubung

Während der Lötarbeit dürfen die Lötverschraubungen nicht am JRGUMAT[®] Thermomischer angebracht sein, da sonst der Thermostat und die Dichtungen beschädigt werden.



Warmwassertemperatur

Um eine einwandfreie Funktion des JRGUMAT[®] Thermomischer gewährleisten zu können, muss die Warmwassertemperatur min. 5 K über der gewünschten Mischwassertemperatur liegen. Ebenso sind hydraulisch gleiche Verhältnisse am Warm- und Kaltwassereingang zwingend. Dies wird durch den Einbau des Mischers in den Wassererwärmer-Kreislauf gemäss unseren Einbauschemen gewährleistet.



Reparaturen

Am JRGUMAT[®] Thermomischer dürfen keine Reparaturen vorgenommen werden.

Nomogramm

Die bei der Rohrweitenbestimmung ermittelte Rohrdimension gilt auch als Nennweite DN für den JRGUMAT[®] Thermomischer. Aus dem Nomogramm können die Beziehungen zwischen Volumenstrom, Nennweite und Druckverlust entnommen werden. Im rasterhinterlegten Bereich herrschen optimale Betriebsbedingungen.

Geräuschverhalten

Dimension	GN ½ DN 15	GN ¾-1¼ DN 20-32
Armaturengruppe	I	II

Transportverpackung = Wärmedämmung

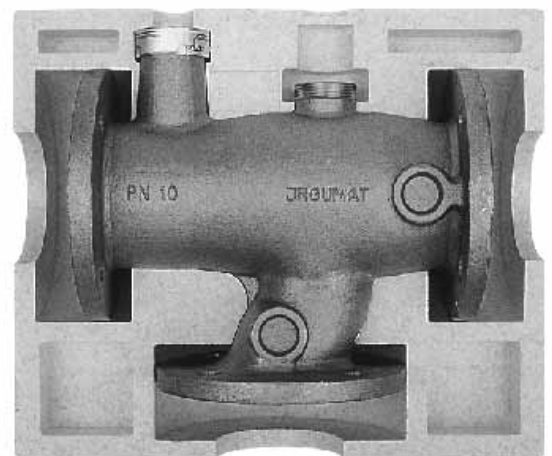
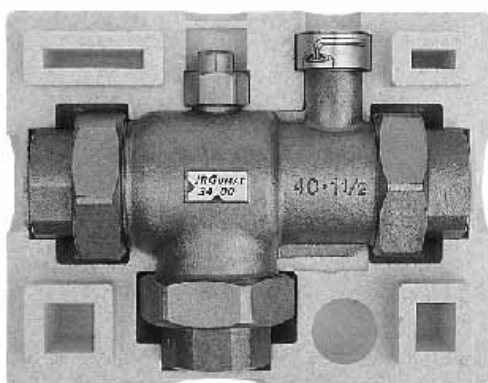

Die Transportverpackungen der JRGUMAT[®] Thermomischer dienen nach der Montage und Einregulierung als Wärmedämmung.

D

Funktion

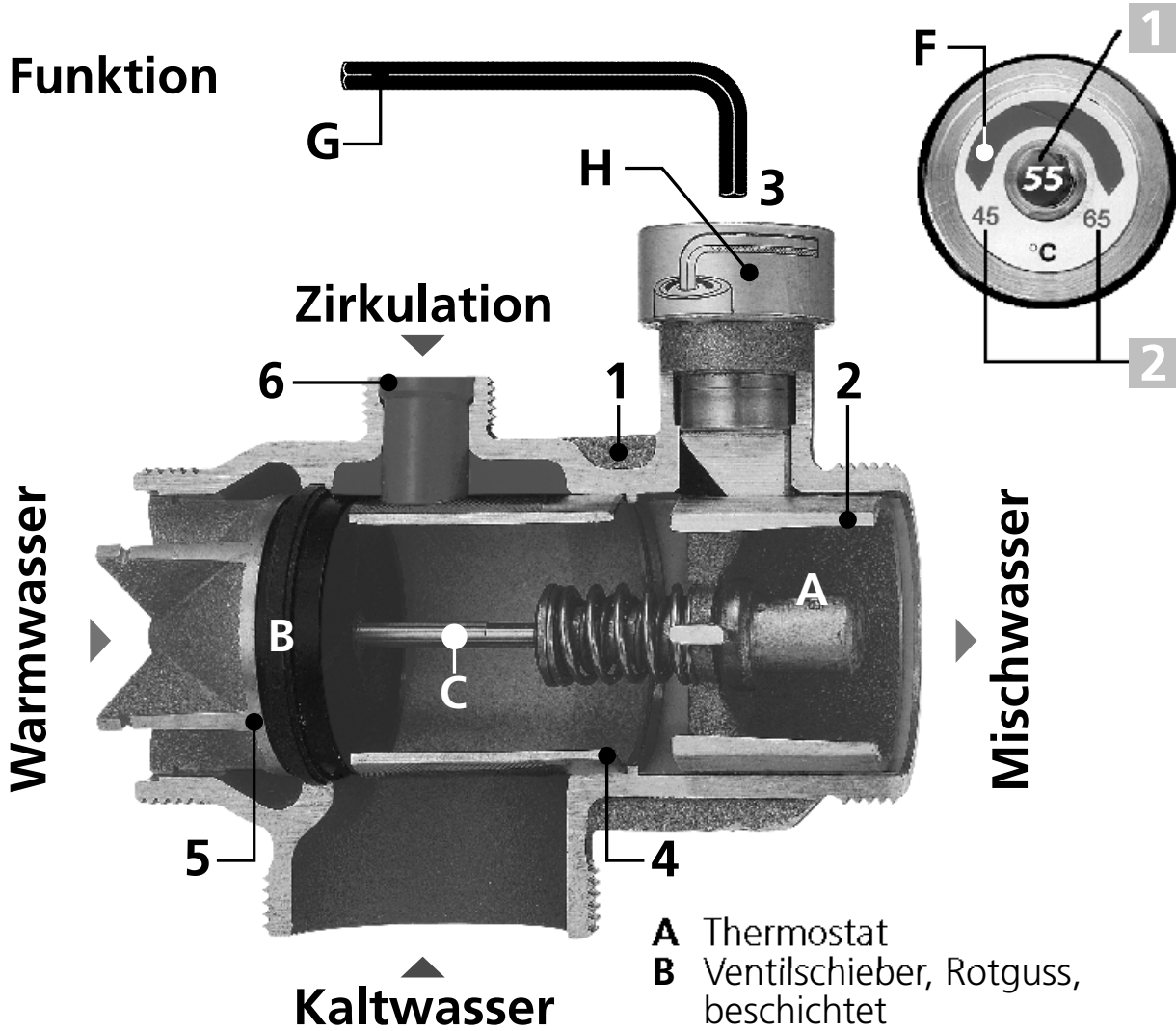

- A** Thermostat
- B** Ventilschieber, Rotguss, beschichtet
- C** Bolzen, Chromnickelstahl
- 1** Gehäuse, Rotguss
- 2** Regulierverschieber, Rotguss
- 3** Einstellschraube, Messing
- 4** Kaltwassersitz, Chromnickelstahl
- 5** Warmwassersitz, Rotguss
- 6** Zirkulationstülle, Kunststoff

1 Standardtemperatur °C	2 Einstellbereiche °C	Änderung der Mischwassertemp. bei 1 Schlüsselumdrehung		
		GN 1/2-1 DN 15-25	GN 1 1/4-2 DN 32-50	DN 65/80
25	20-30	ca. 6 K	ca. 4 K	ca. 2 K
40	30-45			
48	36-53			
55	45-65			

Werkeinstellung/Umstellung

JRGUMAT® Thermomischer sind mit einem der Standardtemperatur zugeordneten Thermostaten ausgerüstet und vom Werk auf eine Standardtemperatur eingestellt. Diese ist aus der Artikelnummer ersichtlich, im Zentrum des Temperaturschildes **F** und auf der Verpackung angegeben. Eine Änderung der Standardtemperatur darf nur innerhalb der Grenzen des zugeordneten Mischwassereinstellbereiches erfolgen.

Dabei wird folgendermassen vorgegangen: Mit dem Sechskantstiftschlüssel **G** wird das Temperaturschild **F** im Zentrum durchstoßen. Durch das Drehen der Schraube **H** im Uhrzeigersinn wird die Mischwassertemperatur erhöht und im Gegenuhrzeigersinn herabgesetzt. Dabei muss der Volumenstrom im rasterhinterlegten Feld "Sollwert-Toleranz $\pm 1\text{K}$ " liegen (siehe Nomogramm).

Wird der Mischer in ein Zirkulationsnetz eingebaut, ist die Zirkulation bei "Nullentnahme" separat einzuregulieren. Hierfür wird erst der Gesamtvolumenstrom der Pumpe (100%) einreguliert. Anschliessend die Volumenströme, welche auf den Mischer führen und der Anteil zur Wärmeverlustdeckung auf den Speicher einstellen. Eine gut einregulierte Zirkulation hält die gewünschte Mischwassertemperatur konstant, auch wenn kein Mischwasser bezogen wird.

D

Mischwasser-Installationsbeispiele

DIN	Text	JRG Nr.	SIA
—	TWK – Kaltwasser – WKR		—
—	TWW – Warmwasser – WWV		— —
—	TWZ – Zirkulation WW – WWR		— . .
—	TWM – Mischwasser – WMV		— . .
—	WMZ– Zirkulation WM – WMR	
●	JRGUMAT® Thermomischer	3400	●
⊗	Absperrventil	5200-34	⊗
▶	Rückschlagventil	1610-15	▶
⊗	Rückflussverhinderer absperrbar	5262-81	⊗
◻	Rückschlagkappe	1682	◻
⚙	Sicherheitsventil	1020-30	⚙
⊗	Regulierorgan	6310	⊗
⊗	JRGUTHERM® Zirkulationsregler	6320	⊗
○	Pumpe		○
⊗←	Entleerhahn	6000-12	⊗←

Ohne Zirkulation mit Heisswasser-Abgang

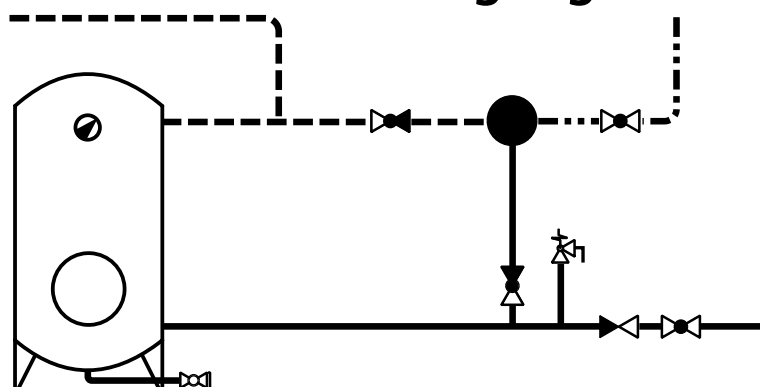

Mit Zirkulation und Heisswasser-Abgang

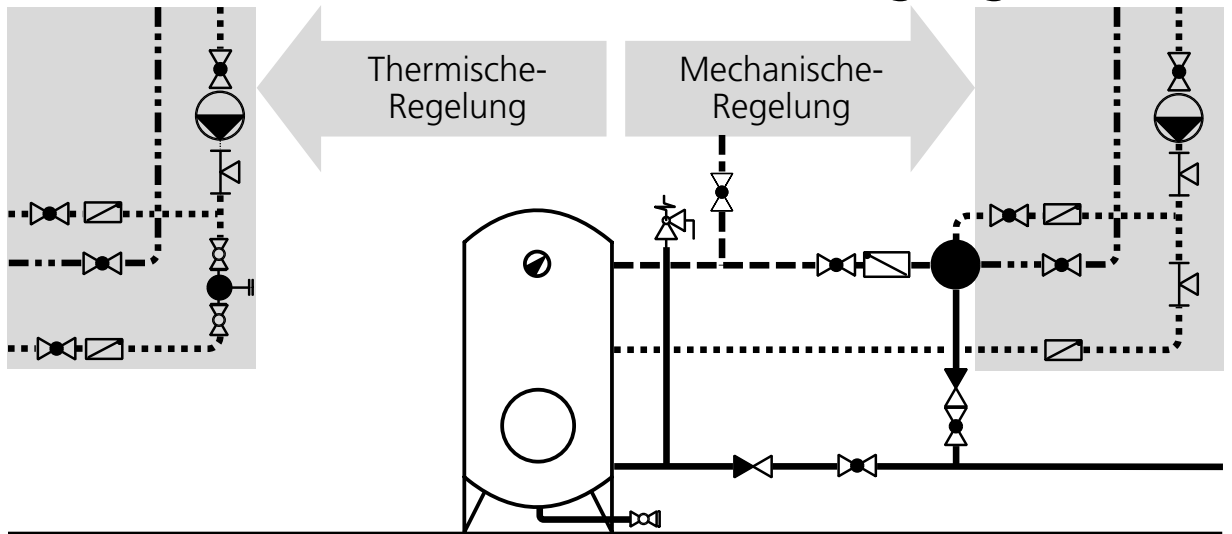

Mit Zirkulation und thermischer Desinfektion

1. Hinweis: Um eine thermische Desinfektion gewährleisten zu können, muss jede Zapfstelle durchflossen, bzw. gespült werden.
2. Hinweis: Für die thermische Desinfektion muss ausreichend heisses Wasser zur Verfügung stehen.



Verbrühungsgefahr

Während der Desinfektion ist der Verbrühungsschutz nicht gewährleistet!

Thermische Desinfektion nur mit JRG LegioTherm® 2T, JRG 3600 möglich.

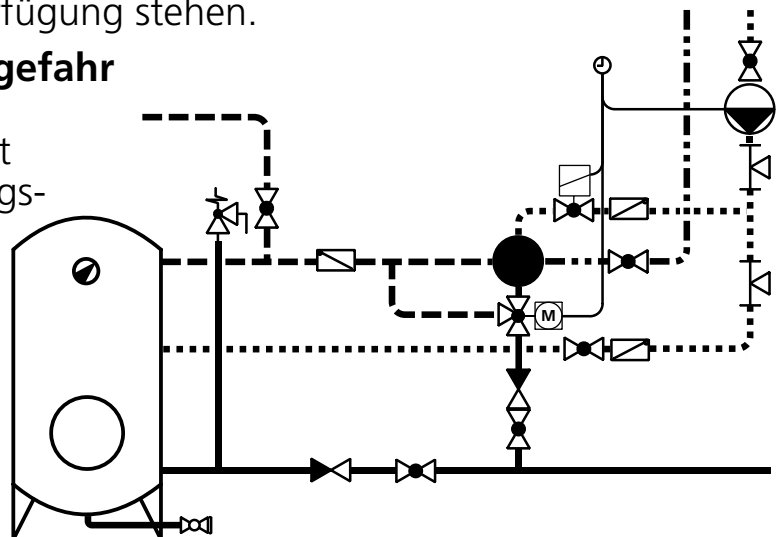

Regelung für die Speicherladung

- 1 Kaltwassereing.
- 2 Warmwassereing.
- 3 Mischwasserausg.
- 4 Zirkulationseing., verschlossen

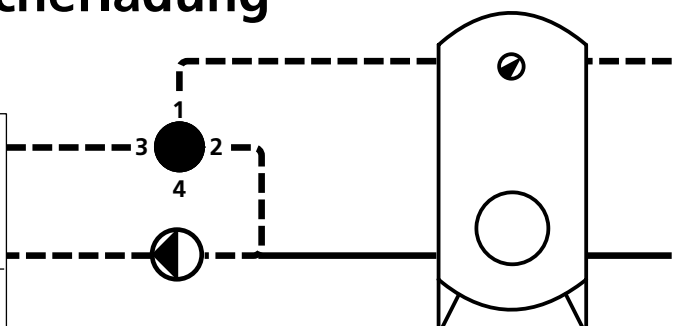
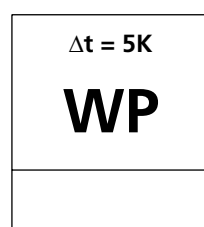

Inbetriebnahme

Vor der Inbetriebnahme des JRGUMAT[®] Thermomischers sind die Leitungen gründlich zu spülen. Mit der Inbetriebnahme der Installation ist der Mischer betriebsbereit.

Wartung

Der JRGUMAT[®] Thermomischer ist wartungsfrei. Am JRGUMAT[®] Thermomischer dürfen keine Reparaturen vorgenommen werden.

Betriebsstörungen

Bei allfällig auftretenden Betriebsstörungen wenden Sie sich bitte an Ihren Sanitär-Installateur.

Vergleichen Sie die Einbausituation mit den Beispielen. Prüfen Sie, ob die gewünschte Mischwassertemperatur bei genügender Entnahme nicht erreicht wird, oder ob die Temperatur im Ruhezustand schwankt. In diesem Falle ist evtl. die Zirkulation ungenügend einreguliert.



Verschraubungen/Dichtungen

Die JRGUMAT® Thermomischer dürfen nur mit flachdichtenden, original JRG Verschraubungen/Dichtungen angeschlossen werden.

AFM 34-Dichtungen dürfen nicht geölt oder gefettet werden.

Fragen?

Für Fragen und anwendungstechnische Auskünfte wenden Sie sich an unsere Technischen Berater oder an den Technischen Kundendienst.

6320



JRGUTHERM®
Zirkulations-
regler

3500/3510



JRGUMAT®
Kompakt-
mischwas-
seranlage

3600



JRG LegioTherm® 2T
Zirkulationsregler

Verlangen Sie unsere detaillierten Unterlagen.

Notice de montage et d'utilisation

Veillez lire attentivement la présente notice de montage et d'utilisation. Voici la signification des symboles utilisés:



Danger

Ce symbole indique la présence d'un risque élevé de blessures à des personnes. Les indications de sécurité doivent être observées.



Avertissement

Ce symbole indique qu'il s'agit d'une information dont le non respect pourrait causer des dommages matériels importants. Les indications de sécurité doivent être observées.



Note

Ce symbole indique qu'il s'agit d'une information contenant des indications importantes sur l'utilisation de l'appareil. Son non respect est susceptible de provoquer des dérangements.

La notice de montage et d'utilisation doit être remise au maître d'ouvrage au moment de la remise de l'installation.

Toutes modifications techniques demeurent réservées en tout temps.

Domaine d'utilisation/fonctionnement

Les mitigeurs thermiques JRGUMAT® ont fait leurs preuves des milliers de fois. Ce sont des vannes mélangeuses à régulation thermique qui s'emploient partout où l'on désire ou l'on exige de l'eau mitigée à température constante avec un haut degré de précision du réglage. Exemples d'utilisation: mitigeur central dans les habitations individuelles ou collectives, hôpitaux, maisons de retraite et de repos, hôtels, casernes, installations de douche d'établissements sportifs, bâtiments industriels ou commerciaux.

Les mitigeurs JRGUMAT® servent aussi de protection contre les températures excessives dans les équipements à énergies alternatives tels que panneaux solaires, chauffages à plaquettes de bois, chaudières à copeaux, fours à pellets, etc. Grâce à la haute précision du réglage de la température, les mitigeurs thermiques JRGUMAT® conviennent également à l'emploi dans des applications spéciales telles que le maintien à température élevée en tant qu'organe de régulation.



Le mitigeur thermique JRGUMAT® est un mélangeur à trois voies à régulation proportionnelle d'architecture ouverte. Les fonctions telles que l'anti-retour, la fermeture ou la régulation du flux volumique circulant ne peuvent pas être assumées par le mitigeur thermique JRGUMAT®. En cas de besoin, il y a lieu de poser les équipements correspondants conformément aux schémas de montage.



Prescriptions de montage

Le mitigeur thermique JRGUMAT® fonctionne dans toutes les positions de montage. Il y a lieu de respecter les prescriptions de montage sur le circuit du chauffe-eau ainsi que les normes applicables au plan local. Seuls les soupapes de retenue indiquées dans les schémas peuvent être montées. Comme vannes d'arrêt, seules peuvent être utilisées les vannes à faible perte de pression telles que les vannes à siège oblique, les vannes à coulisseau et les robinets sphériques.

Les conduites doivent être complètement rincées et purgées avant le montage du mitigeur thermique JRGUMAT®. Afin d'éviter tout défaut de fonctionnement du mitigeur en raison de chaleur rayonnée, celui-ci doit être installé à côté du chauffe-eau et à au moins un mètre de distance entre le mitigeur JRGUMAT® et le chauffe-eau. Si une distance minimale ne peut pas être respectée, il convient d'installer un thermosiphon.



Anti-retour

Seuls des vannes anti-retour à faible chute de pression JRG 1611-1615, clapets anti-chocs JRG 1682 et vannes anti-retour pouvant être fermées JRG 5262-5281 peuvent être utilisées pour le raccordement du mitigeur thermique JRGUMAT®.



Filetages soudés

Pendant les travaux de soudure, les raccords soudés ne doivent pas être fixés au mitigeur thermique JRGUMAT[®], au risque d'endommager le thermostat et les joints.



Température de l'eau chaude

Afin d'assurer le fonctionnement impeccable du mitigeur thermique JRGUMAT[®], la température de l'eau chaude doit être d'au moins 5 °K au-dessus de la température désirée pour l'eau mitigée. De même, les conditions hydrauliques doivent être les mêmes à l'arrivée d'eau chaude et à l'arrivée d'eau froide, ce dont on s'assurera en procédant au montage du mitigeur dans le circuit du chauffe eau comme indiqué dans les schémas de montage.



Réparations

Il ne doit être procédé à aucunes réparations sur le mitigeur thermique JRGUMAT[®].

Nomogramme

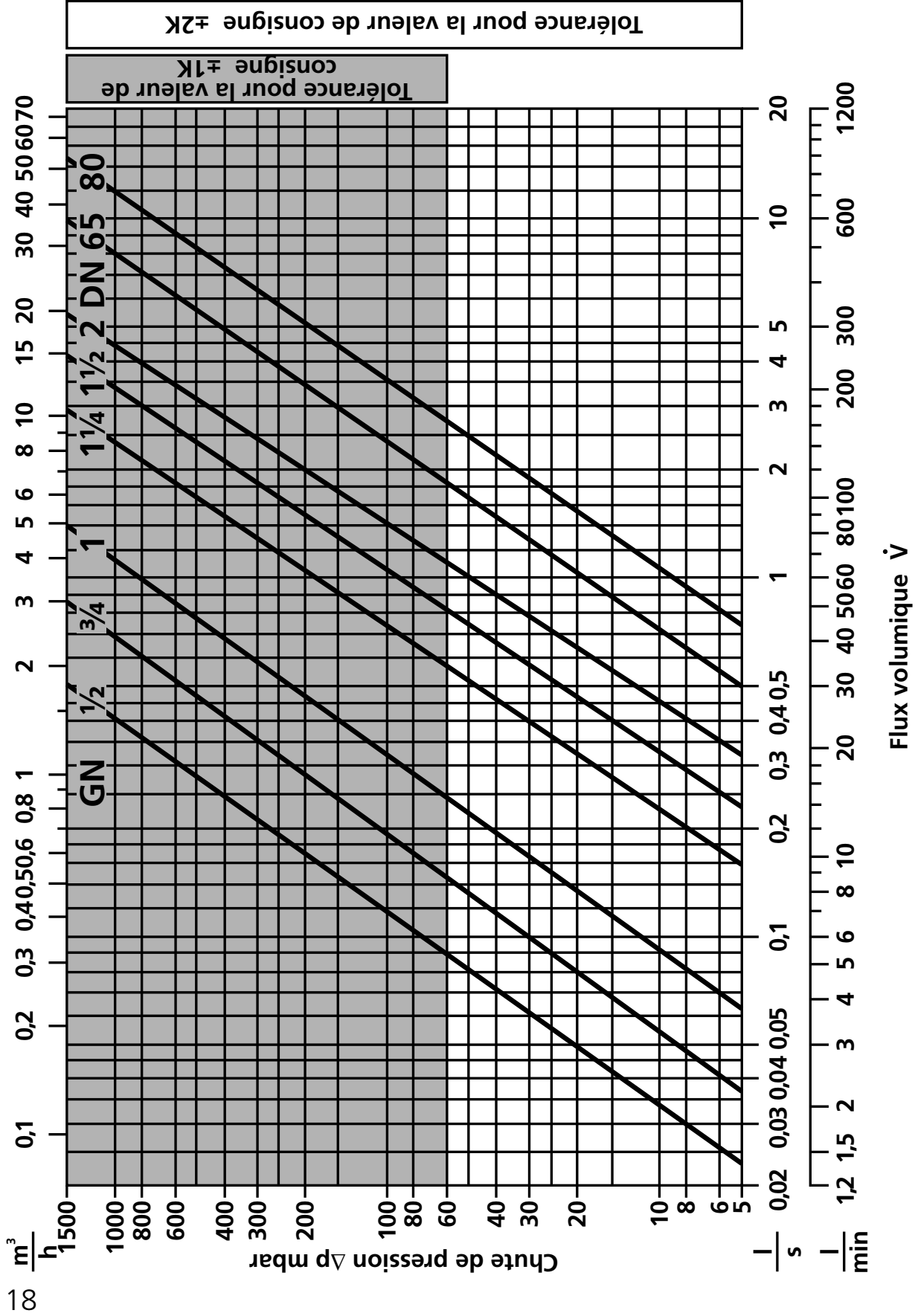

Nomogramme

La dimension des tubes déterminées lors du calcul du diamètre des tubes vaut également comme diamètre nominal DN pour le mitigeur thermique JRGUMAT®. Les relations entre le flux volumique, le diamètre nominal et la chute de pression peuvent être tirées du nomogramme. La partie hachurée dénote des conditions de fonctionnement optimales.

Comportement phonique

Dimension	GN ½ DN 15	GN ¾-1¼ DN 20-32
Gr. de robinetterie	I	II

Emballage de transport = isolation thermique

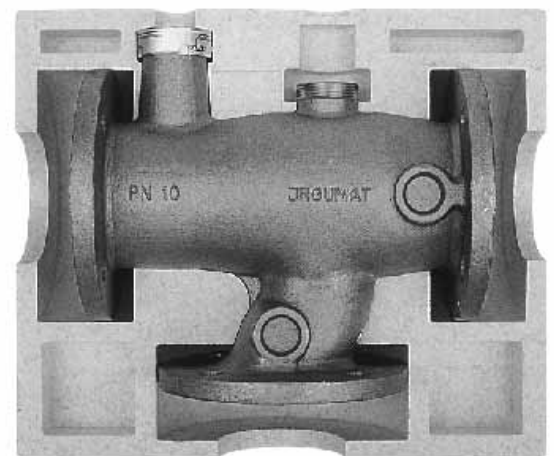
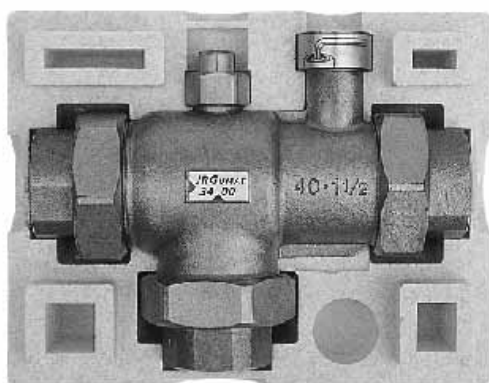

Les emballages pour le transport des mitigeurs thermiques JRGUMAT® servent d'isolation thermique après la pose et le réglage du mitigeur.

F

Fonctionnement

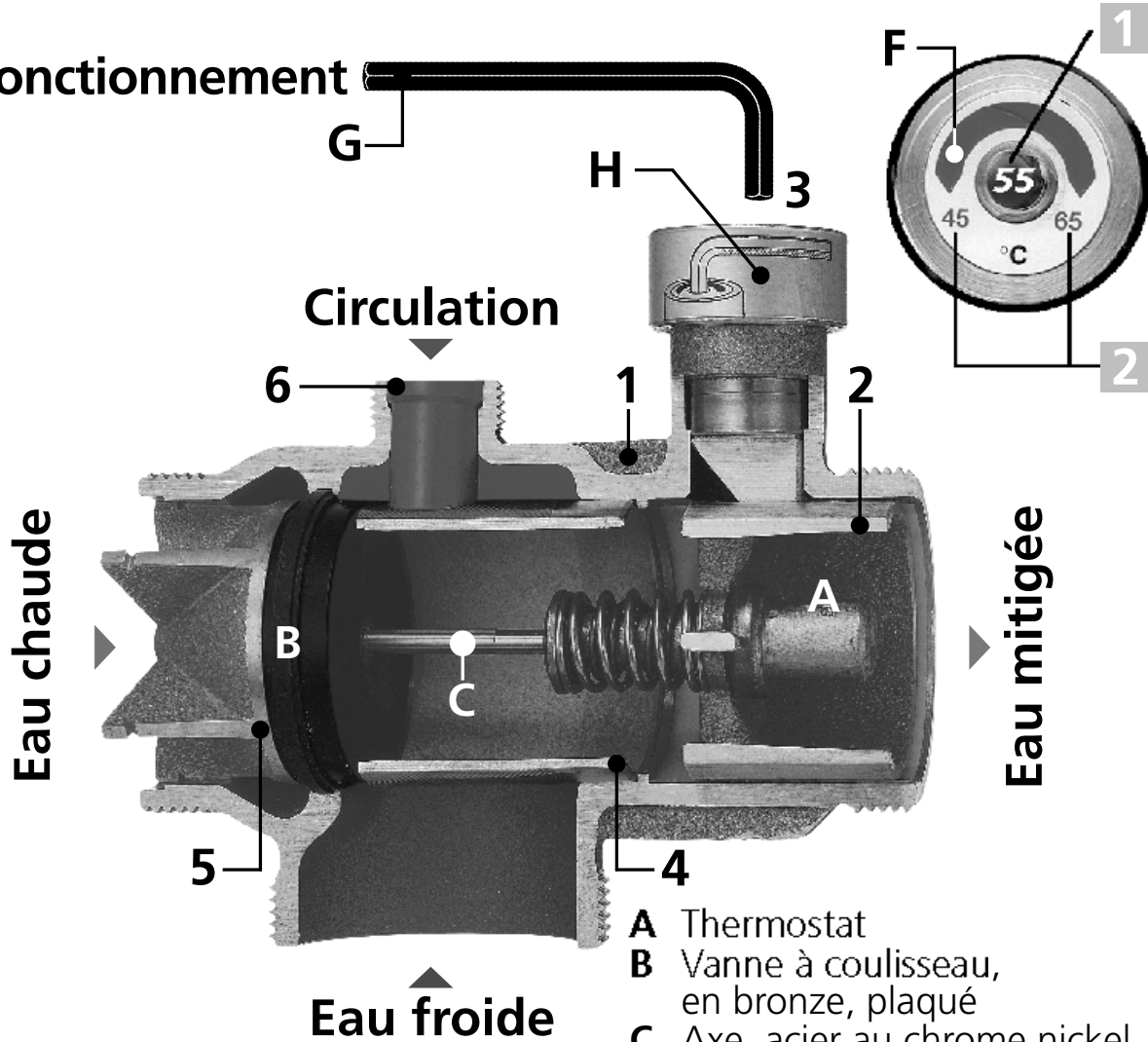

- A Thermostat
- B Vanne à coulisseau, en bronze, plaqué
- C Axe, acier au chrome nickel
- 1 Boîtier, en bronze
- 2 Coulisseau de réglage, en bronze
- 3 Vis de réglage, laiton
- 4 Base eau froide, acier au chrome nickel
- 5 Base eau chaude, en bronze
- 6 Gaine de circulation, matière synthétique

1 Températur. standard °C	2 Plages de réglage °C	Modification de la températ. de l'eau mitigée pour un tour de clé		
		GN ½-1 DN 15-25	GN 1¼-2 DN 32-50	DN 65/80
25	20-30			
40	30-45			
48	36-53	Env. 6 K	Env. 4 K	Env. 2 K
55	45-65			

Réglages d'usine/changement des réglages

Les mitigeurs thermiques JRGUMAT® sont équipés d'un thermostat affecté à une température standard et réglé d'usine à une température standard.

Celle-ci est indiquée par le numéro d'article, au centre de la plaquette de température **F** et sur l'emballage.

Toute modification de la température standard ne peut intervenir que dans les limites de la plage de réglage de la température de l'eau mitigée.

Procéder comme suit: à l'aide de la clé mâle à six pans **G**, percer en son centre la plaquette de température **F**.















La température de l'eau mitigée est augmentée en tournant la vis **H** dans le sens des aiguilles d'une montre, et abaissée en tournant dans le sens contraire. Il faut ce faisant que le flux volumique se situe dans la zone hachurée « Tolérance pour la valeur de consigne ± 1 K » (voir le nomogramme).

Si le mitigeur est monté dans un réseau de circulation, il y a lieu de régler séparément la circulation à « prélèvement zéro ». Pour ce faire, on commence par régler le flux volumique total de la pompe (100 %).

On règle ensuite les flux volumiques menant au mitigeur et la part de couverture de la perte thermique de l'accumulateur. Une circulation bien réglée maintient constante la température de l'eau mitigée, même en l'absence de prélèvement.

F

Exemple d'installation pour l'eau mitigée

DIN	Texte	No. JRG	SIA
	TWK – Eau froide – WKR		
	TWW – Eau chaude – WWV		
	TWZ – Circulation WW – WWR		
	TWM – Eau mitigée – WMV		
	WMZ – Circulation WM – WMR		
	Mitigeur JRGUMAT [®]	3400	
	Vanne d'arrêt	5200-34	
	Vanne de retenue	1610-15	
	Soup. de ret. avec disp. d'arrêt	5262-81	
	Clapet de retenue	1682	
	Soupape de sécurité	1020-30	
	Té de réglage	6310	
	Régulateur de circ. JRGUTHERM [®]	6320	
	Pompe		
	Vanne de vidange	6000-12	

Sans circulation, avec sortie eau chaude

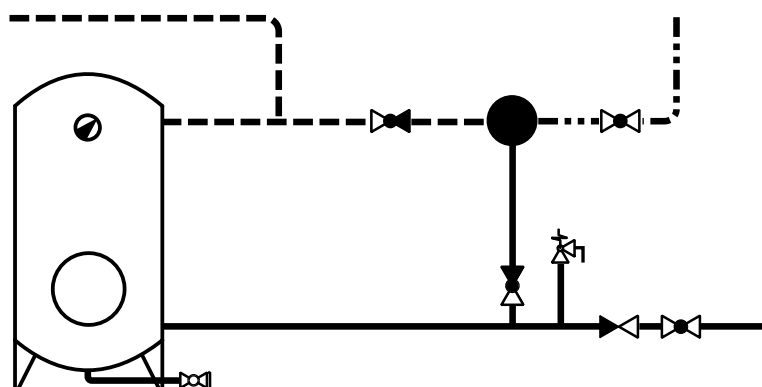

Avec circulation et sortie eau chaude

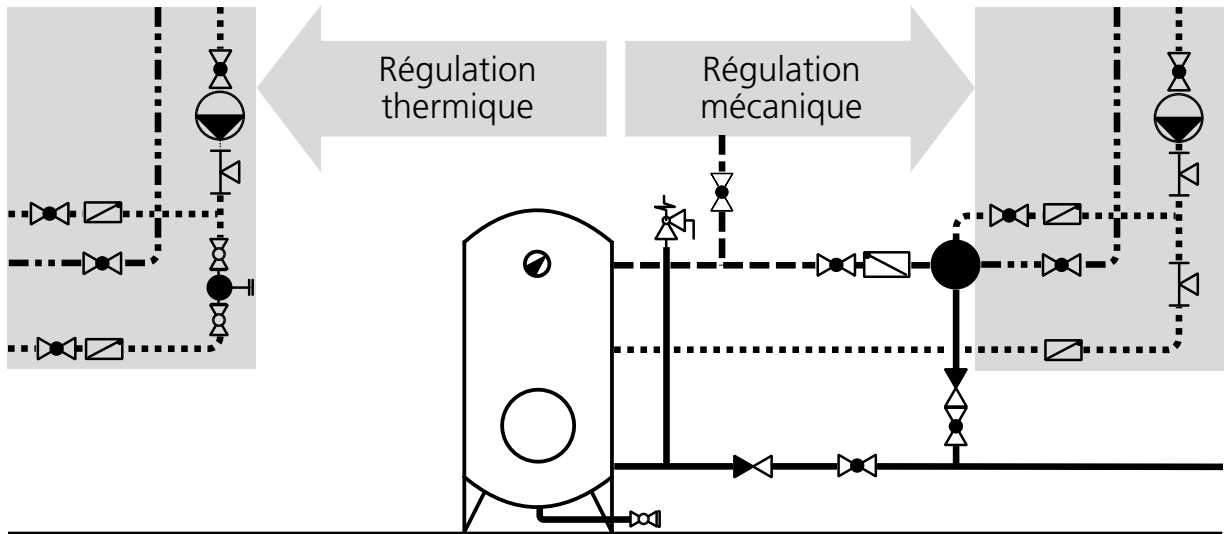

Avec circulation et désinfection thermique

Note 1: Afin de pouvoir assurer la désinfection thermique, chaque point de prélèvement doit être rincé ou purgé.

Note 2: Il faut disposer de suffisamment d'eau chaude pour pouvoir assurer la désinfection thermique.



Risque de brûlure

La protection contre les brûlures n'est pas assurée pendant la désinfection thermique!

La désinfection thermique à l'aide de l'appareil JRG LegioTherm® 2T, JRG 3600 possible.

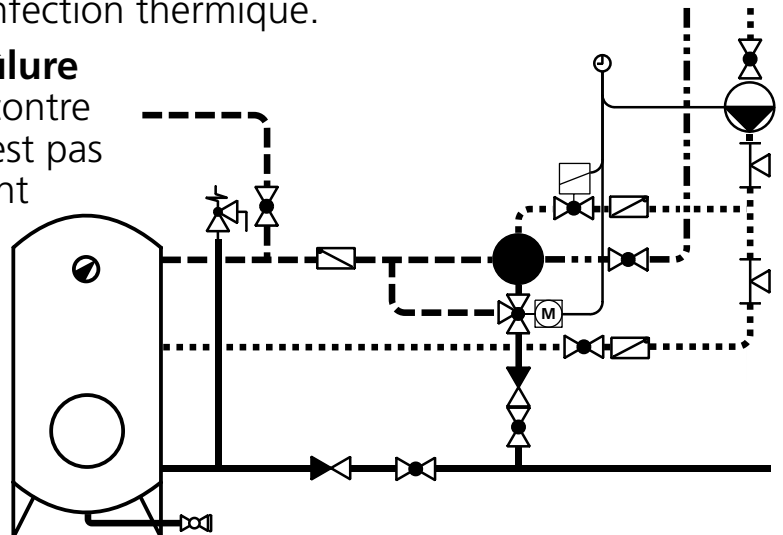

Régulation pour la charge de l'accumulateur

- 1 Arr. de l'eau froide
- 2 Arr. de l'eau chaude
- 3 Sort. de l'eau mitig.
- 4 Entrée de la circulation: fermée

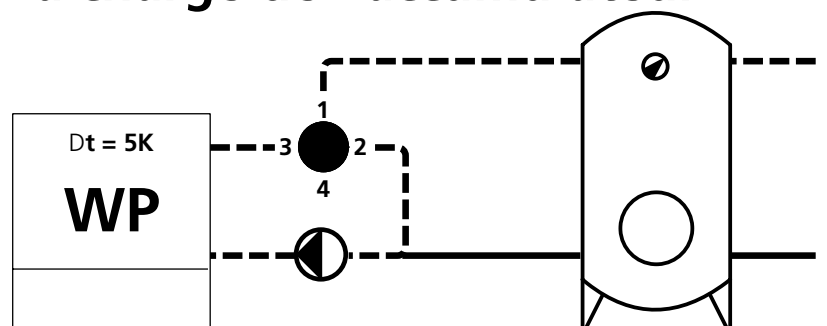

Mise en service

Il y a lieu de rincer à fond les conduites avant la mise en service du mitigeur thermique JRGUMAT®.

Le mitigeur thermique est prêt à fonctionner dès la mise en service de l'installation.

Maintenance

Le mitigeur thermique JRGUMAT® est exempt d'entretien. Aucune réparations ne doivent être effectuées sur les mitigeurs thermiques JRGUMAT®.

Dérangements

Veillez vous adresser à votre installateur sanitaire en cas de dérangements dans le fonctionnement du mitigeur.

Comparez la situation effective de montage avec les exemples. Vérifiez, si la température désirée de l'eau mitigée n'est pas obtenue en présence de prélèvement suffisant, si la température varie au repos. Dans ce cas, il est possible que la circulation soit mal réglée.



Filetages/Joints

Les mitigeurs thermiques JRGUMAT® ne doivent être raccordés qu'avec des filetages et joints étanches plats JRG d'origine.

Les joints AFM 34 ne doivent être ni huilés, ni graissés.

Avez-vous des questions?

N'hésitez pas à vous adresser à nos conseillers techniques ou à notre service technique après-vente si vous avez des questions ou si vous désirez des renseignements techniques d'application.

6320



JRGUTHERM®
Régulateur de
circulation

3500/3510



JRGUMAT®
Installation
compacte
d'eau
mitigée

3600



JRG LegioTherm® 2T
Régulateur de circulation

Demandez notre documentation détaillée.

Istruzioni per il montaggio e l'uso

Vi preghiamo di leggere attentamente le presenti istruzioni per il montaggio e l'uso. I simboli impiegati nel testo hanno i significati seguenti:



Pericolo

Questo simbolo segnala un alto rischio di lesioni alle persone. Attenersi alle istruzioni relative alla sicurezza.



Avvertimento

Questo simbolo segnala un'informazione, la mancata osservanza della quale può causare importanti danni alle cose. Attenersi alle istruzioni relative alla sicurezza.



Avviso

Questo simbolo segnala un'informazione contenente importanti dati relativi all'impiego. La mancata osservanza può causare guasti.

Le Istruzioni per il montaggio e l'uso vanno consegnate al committente al momento della consegna dell'impianto.

Con riserva di modifiche tecniche in qualsiasi momento.

Campo d'applicazione/Funzione

I termomiscelatori JRGUMAT[®], collaudati migliaia di volte, sono valvole miscelatrici per la regolazione termostatica, impiegabili dappertutto dove è desiderata e pretesa una temperatura dell'acqua miscelata con un'alta precisione di regolazione.

Per esempio, come miscelatori centrali in case mono- e plurifamiliari, ospedali, case per anziani e di cura, alberghi, caserme, impianti docce per installazioni sportive, edifici industriali e artigianali.

I termomiscelatori JRGUMAT[®] servono anche da protezione termica negli impianti di energia alternativa, come: impianto solari, riscaldamenti a legna di piccola pezzatura, bruciatori a scarti di legno, forni a pellet, ecc. Grazie all'alta precisione di regolazione, i termomiscelatori JRGUMAT[®] sono usati anche in applicazioni speciali, come per es. come organi di regolazione per mantenere l'alta temperatura.



Il termomiscelatore JRGUMAT[®] è un miscelatore a tre vie per la regolazione proporzionale in architettura aperta. Funzioni come antiriflusso, bloccaggio oppure la regolazione di circolazione della portata in volume non possono invece essere affidate ai termomiscelatori JRGUMAT[®]. Per queste funzioni, occorre installare le rubinetterie idonee conformemente agli schemi d'installazione.



Prescrizioni per l'installazione

Il termomiscelatore JRGUMAT® funziona in qualsiasi posizione è installato. Attenersi alle prescrizioni relative al circuito degli scaldacqua, come pure le norme locali.

Possono essere installati soltanto i dispositivi antiritorno prescritti dagli schemi.

Come valvole d'arresto si possono installare unicamente valvole a minima perdita di pressione, come quelle a sede obliqua, otturatori e rubinetti a sfera.

Prima dell'installazione del termomiscelatore JRGUMAT® occorre risciacquare a fondo le condotte. Per impedire il funzionamento errato del miscelatore in seguito a calore radiante, occorre posizionarlo lateralmente allo scaldacqua, mantenendo almeno un metro di distanza da esso. Una distanza minima non può essere rispettata, deve essere installato un termosifone. Le istruzioni d'uso e di montaggio allegate sono da rimettere al committente alla consegna dell'impianto.



Dispositivi antiritorno

Per l'allacciamento dei termomiscelatori JRGUMAT® possono essere utilizzati unicamente valvole antiritorno a bassa perdita di pressione JRG 1611-1615, valvole di ritegno JRG 1682 e dispositivi antiritorno bloccabili JRG 5262-5281.



Raccordo a vite saldato

Per i lavori di brasatura, i raccordi a vite non devono essere montati sul termomiscelatore JRGUMAT[®], per evitare di danneggiare il termostato e le guarnizioni di tenuta.



Temperatura dell'acqua calda

Per garantire il perfetto funzionamento del termomiscelatore JRGUMAT[®] occorre che la temperatura dell'acqua calda sia almeno 5 K sopra quella richiesta per l'acqua miscelata. Sono altrettanto coercitivi le stesse condizioni, dal punto di vista idraulico, per le immissioni dell'acqua calda e fredda. Il rispetto di queste condizioni è assicurato dall'installazione, conforme ai nostri schemi d'installazione, del miscelatore nel circuito dello scaldacqua.



Riparazioni

È vietato procedere a riparazioni del termomiscelatore JRGUMAT[®].

Nomogramma

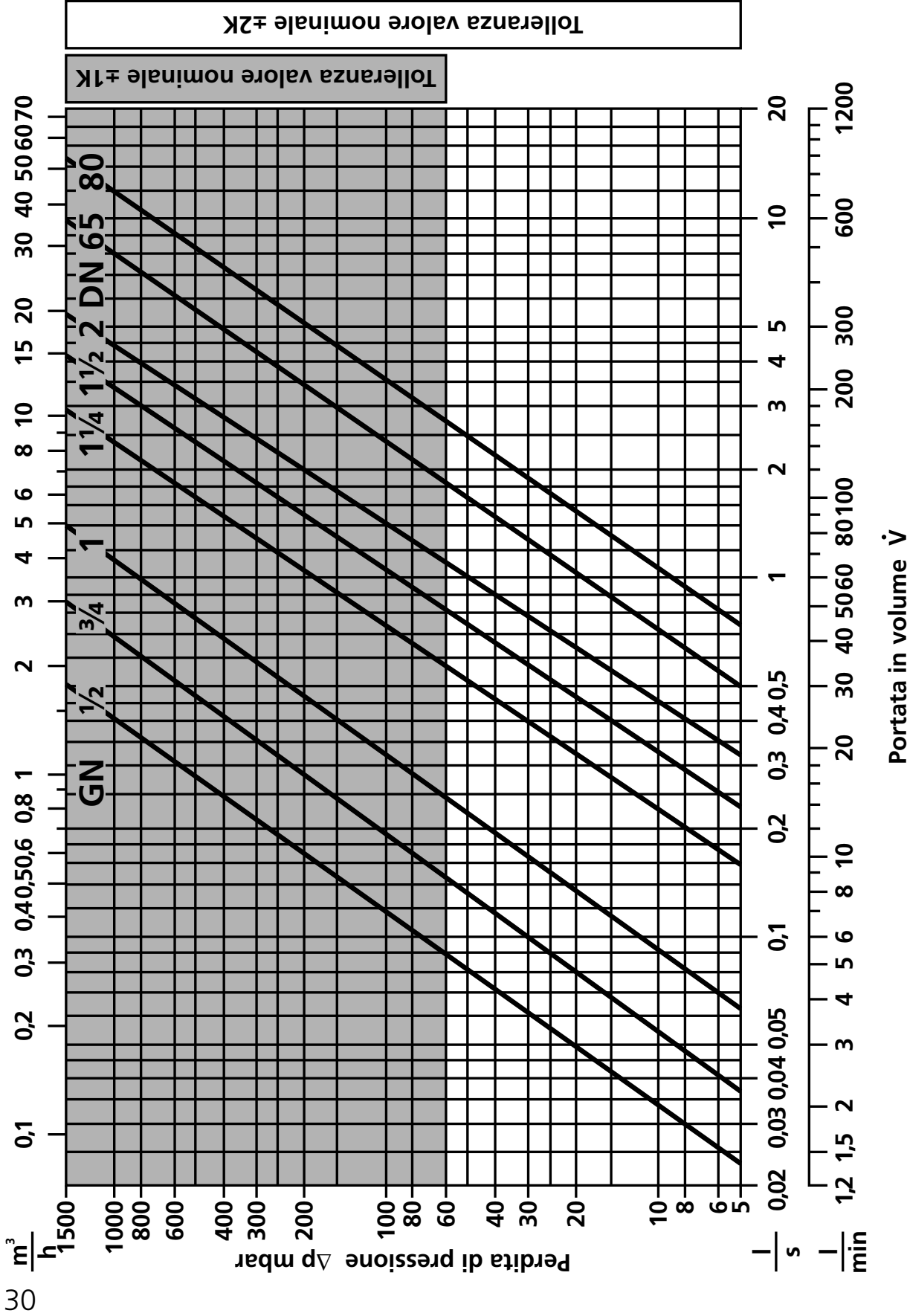

Nomogramma

La dimensione del tubo, stabilita determinando il diametro delle condotte, vale anche come diametro nominale DN per il termomiscelatore JRGUMAT®. Dal nomogramma si possono dedurre i rapporti fra portata in volume, diametro nominale e perdita di pressione. Nel settore retinato regnano condizioni di funzionamento ottimali.

Rumorosità

Dimensione	GN ½ DN 15	GN ¾-1¼ DN 20-32
Grup. rubinetterie	I	II

Imballaggio di trasporto = isolamento termico

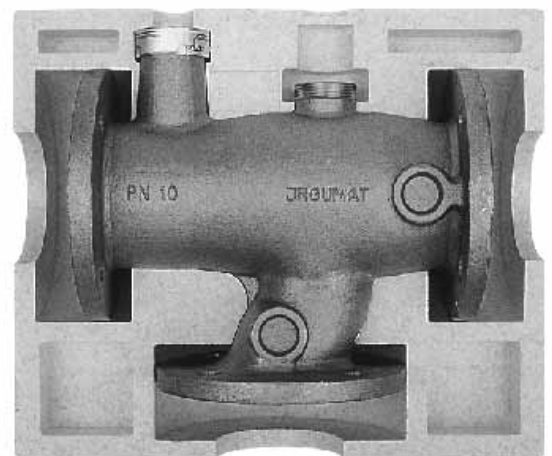
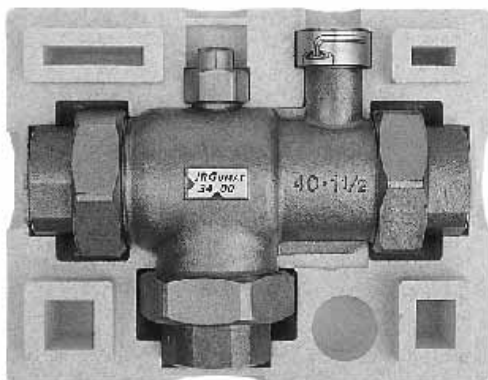

Gli imballaggi per il trasporto dei termomiscelatori JRGUMAT® servono da isolamento termico dopo il montaggio e l'aggiustamento.

Funzione

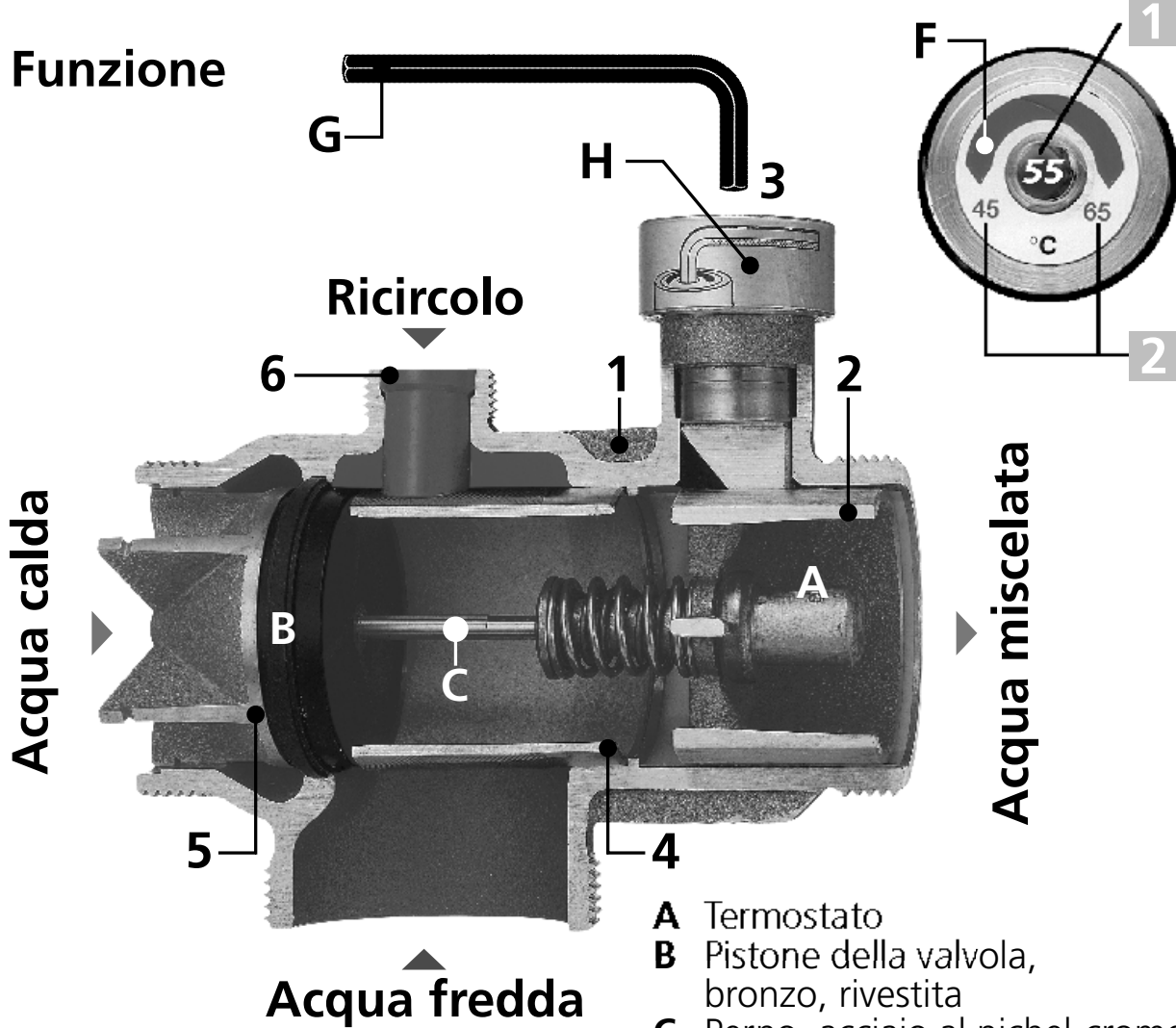

- A** Termostato
B Pistone della valvola, bronzo, rivestita
C Perno, acciaio al nichel-cromo
1 Corpo della valvola, bronzo
2 Regolatore, bronzo
3 Vite di aggiustamento, ottone
4 Sede acqua fredda, acciaio al nichel-cromo
5 Sede acqua calda, bronzo
6 Pressa acqua di ricircolo, mat. plastica

1 Temperatura standard °C	2 Campi di regolazione °C	Variazione della temp. acqua miscelata con 1 giro di chiave		
		GN 1/2-1 DN 15-25	GN 1 1/4-2 DN 32-50	DN 65/80
25	20-30	ca. 6 K	ca. 4 K	ca. 2 K
40	30-45			
48	36-53			
55	45-65			

Regolazione di fabbrica/Modifiche

I termomiscelatori JRGUMAT® sono equipaggiati di termostato correlato alla temperatura standard e regolato in fabbrica su una temperatura standard. Questa figura nel numero d'articolo, al centro della targhetta della temperatura **F** ed è indicata anche sull'imballaggio. Una modifica della temperatura standard può avvenire unicamente entro i limiti del campo di regolazione dell'acqua miscelata correlato. Per la modifica, procedere come segue: con la chiave maschio esagonale **G** si perfora al centro la targhetta della temperatura **F**. Facendo ruotare la vite **H** in senso orario, si aumenta la temperatura dell'acqua miscelata, mentre ruotando la vite in senso antiorario, la temperatura diminuisce. Badare che la portata in volume si situi nel campo retinato "Tolleranza valore nominale $\pm 1K$ " (vedere il nomogramma). Se il miscelatore è installato in una rete di ricircolo, occorre regolare separatamente il ricircolo su "Prelievo zero". A questo scopo, si aggiusta dapprima la portata in volume complessiva della pompa (100%). In seguito, aggiustare sia le portate in volume in arrivo al miscelatore, sia la quota per coprire la perdita termica del bollitore. Un ricircolo ben regolato mantiene costante la temperatura dell'acqua miscelata, anche se non vi è prelievo di quest'ultima.

Esempi d'installazione per acqua miscelata

DIN	Testo	JRG No.	SIA
—	TWK – acqua fredda – WKR		—
—	TWW – acqua calda – WWV		— —
—	TWZ – ricircolo WW – WWR		— . .
—	TWM – acqua miscelata – WMV		— . .
—	WMZ – ricircolo WM – WMR	
●	Termomiscelatore JRGUMAT®	3400	●
⊗	Valvola d'arresto	5200-34	⊗
▶	Valvola antiritorno	1610-15	▶
⊗	Dispositivo antiritorno bloccabile	5262-81	⊗
⊗	Valvola antiritorno	1682	⊗
⚠	Valvola di sicurezza	1020-30	⚠
⊗	Organo di regolazione	6310	⊗
⊗	Regol. di ricircolo JRGUTHERM®	6320	⊗
⊙	Pompa		⊙
⊗←	Rubinetto di scarico	6000-12	⊗←

Senza ricircolo con uscita acqua bollente

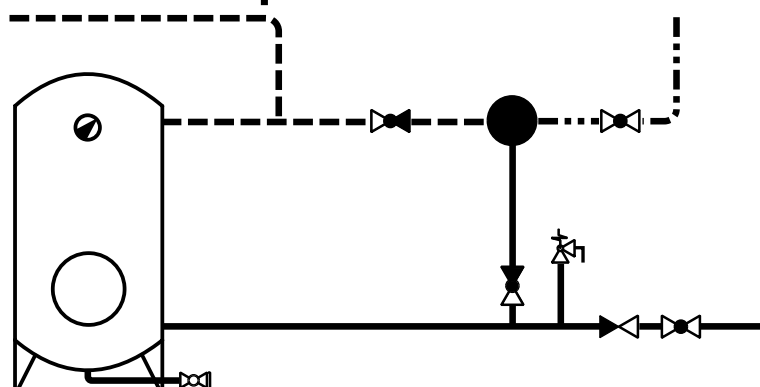

Con ricircolo e uscita acqua bollente

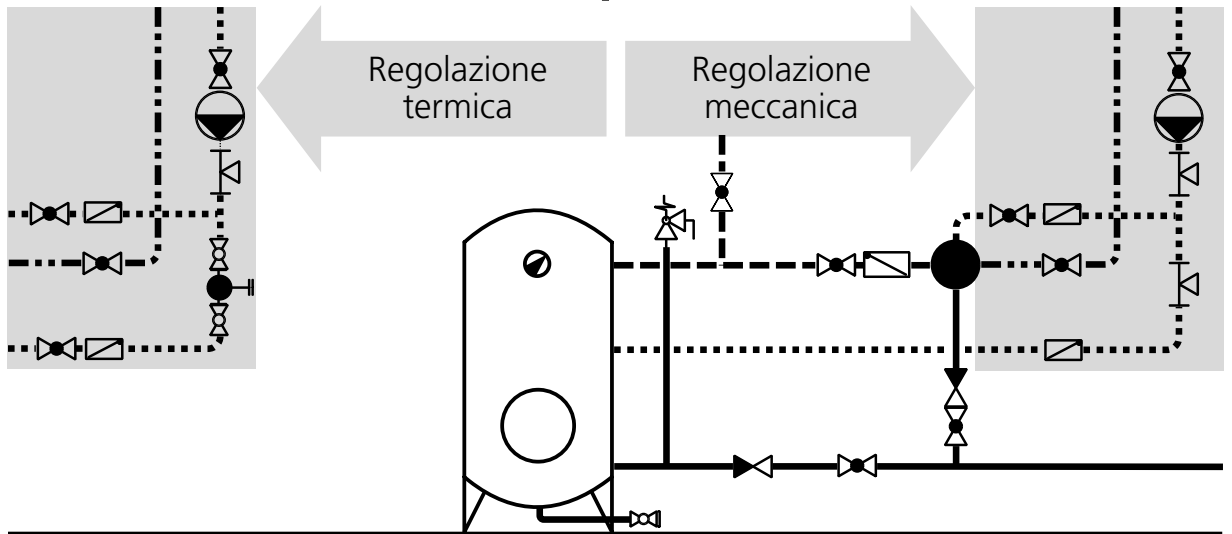

Con ricircolo e disinfezione termica

- 1a indicazione: per garantire la disinfezione termica, occorre che ogni punto di prelievo sia risciacquato a fondo.
- 2a indicazione: per la disinfezione termica occorre che sia disponibile una sufficiente quantità d'acqua.



Pericolo di scottature

Durante la disinfezione, la protezione dalle scottature non è assicurata!

La disinfezione termica è possibile soltanto con JRG LegioTherm® 2T, JRG 3600.

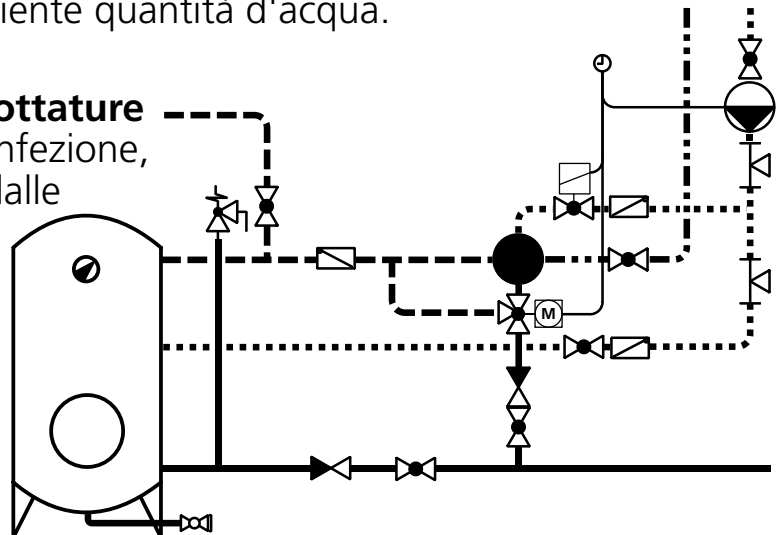

Regolazione per caricare il serbatoio

- 1 Entrata acqua fredda
- 2 Entrata acqua calda
- 3 Uscita acqua miscel.
- 4 Entrata ricircolo, chiusa

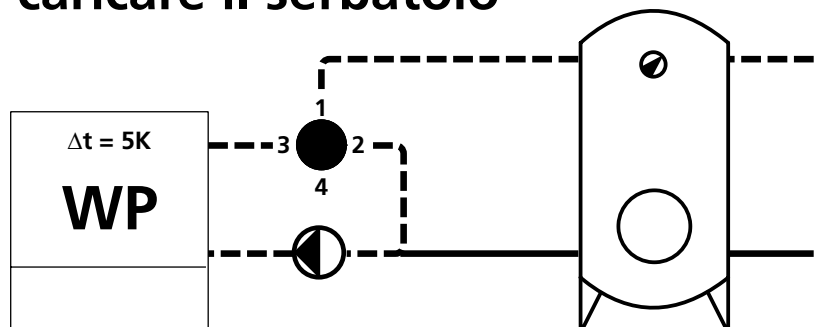

Messa in esercizio

Prima di mettere in esercizio il termomiscelatore JRGUMAT® occorre risciacquare a fondo le condotte. Con la messa in esercizio dell'installazione, il miscelatore è pronto a entrare in funzione.

Manutenzione

Il termomiscelatore JRGUMAT® non richiede manutenzione.

È vietato procedere a riparazioni di qualsiasi genere sul termomiscelatore JRGUMAT®.

Guasti di funzionamento

In caso di guasti di funzionamento, rivolgetevi al vostro installatore sanitario.

Comparete la situazione d'installazione con gli esempi. Verificate se la voluta temperatura dell'acqua miscelata non viene raggiunta con un prelievo sufficiente, oppure se la temperatura varia in condizione di riposo. In questo caso, vuol dire che la circolazione è insufficientemente aggiustata.



Raccordi a vite/Guarnizioni di tenuta

I termomiscelatori JRGUMAT® vanno allacciati esclusivamente mediante raccordi a vite/guarnizioni di tenuta a piatto originali JRG.

Le guarnizioni AFM 34 non devono essere lubrificate con olio o grasso.

Avete ancora delle domande?

Se avete ancora domande o vi occorrono informazioni relativi all'impiego, vi preghiamo di rivolgervi ai nostri consulenti tecnici oppure al servizio tecnico di assistenza ai clienti.

6320



Regolatore di ricircolo JRG GUTHERM®

3500/3510



Impianto compatto di miscelazione acqua JRGUMAT®

3600



Regolatore di ricircolo JRG LegioTherm® 2T

Richiedete le nostre documentazioni dettagliate.

Installation and operating instructions

Please read these installation and operating instructions carefully. The symbols used have the following meanings:



Danger

This symbol indicates a serious risk of personal injury. Please follow the safety pointers given.



Warning

This symbol refers to information that can result in serious material damage if not followed. Please follow the safety pointers given.



Note

This symbol refers to information that contains important data relating to usage. Failure to comply can lead to malfunctions.

The installation and operating instructions must be given to the building owner when the installation is commissioned.

The company reserves the right to amend product specifications at any time.

Field of application/Function

JRGUMAT[®] thermoblending valves are tried-and-tested thermostatic mixing valves that are used wherever a constant water temperature of high controllable accuracy is required. For example, as central mixing valves in family homes and apartment buildings, hospitals, old-age and nursing homes, hotels, barracks, showering facilities at sports grounds, on commercial and industrial premises. JRGUMAT[®] thermoblending valves can also be used to protect against excess temperatures in alternative energy installations such as solar-heating installations, log heating systems, wood-chip heating systems, wood pellet stoves and furnaces, etc. Thanks to their high controllability, JRGUMAT[®] thermoblending valves are also used for special applications such as, for example, maintaining high temperatures as regulating units.



JRGUMAT[®] thermoblending valves are proportionally regulating, open architecture, three-way mixing valves. JRGUMAT[®] thermoblending valves cannot be used as check valves or stop valves nor can they be used to regulate flow rates. The appropriate valves must be installed as shown in the layout drawings.



Installation instructions

JRGUMAT[®] thermoblending valves will operate in any position. The installation regulations relating to the water heater circulation as well as local standards must be complied with. Only the non-return valves prescribed in the diagrams may be used. The only stop valves permissible are low pressure-loss valves, such as slanted seat valves, gate valves and ball valves.

All pipes must be flushed thoroughly before JRGUMAT[®] thermoblending valves are installed. In order to prevent a JRGUMAT[®] mixing valve from malfunctioning due to radiated heat, the valve should be located at least one metre away from the heater. If a minimum separation cannot be guaranteed, a thermosiphon must be installed.



Return-flow prevention

When connecting JRGUMAT[®] thermoblending valves, only JRG type 1611-1615 low pressure-loss check valves, JRG type 1682 swing check valves and JRG type 5262-5281 closable non-return valves may be used.



Soldering unions

When carrying out soldering work, it is essential to remove a JRGUMAT[®] thermobleshooting valve from the unions as the thermostat and the seals would otherwise be damaged.



Hot water temperature

To ensure that your JRGUMAT[®] thermobleshooting valves operate correctly, the warm water temperature must be at least 5 K above the desired blended water temperature. Identical hydraulic conditions are essential at the hot and cold water feeds. This is ensured by installing the mixing valves in the water heater circuit as shown in our installation drawings.



Repairs

No attempts should be made to repair JRGUMAT[®] thermobleshooting valves.

Nomogramme

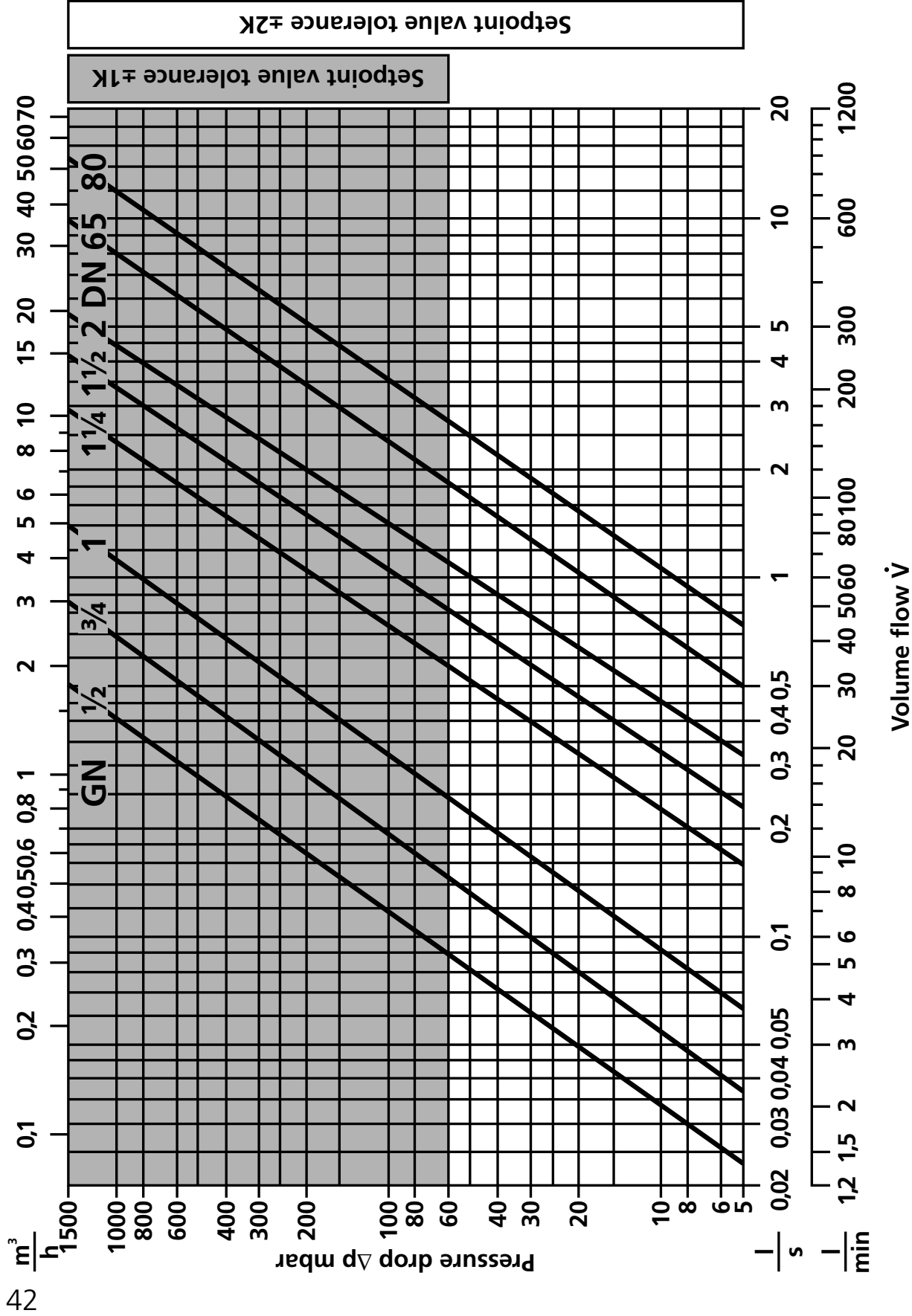

Nomogramme

The size of piping used is considered the nominal value DN for a JRGUMAT® thermoblending valve. The relationships between flow rate, nominal size and pressure loss are given in the nomogram. Optimum operating conditions are to be found in the hatched area.

Noise behaviour

Dimension	GN ½ DN 15	GN ¾-1¼ DN 20-32
Valve group	I	II

Transport packaging = thermal insulation

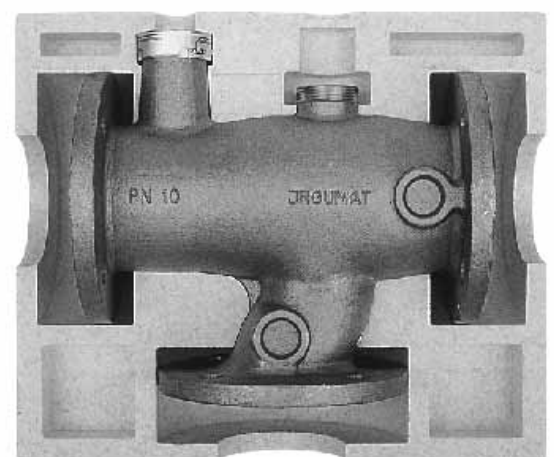
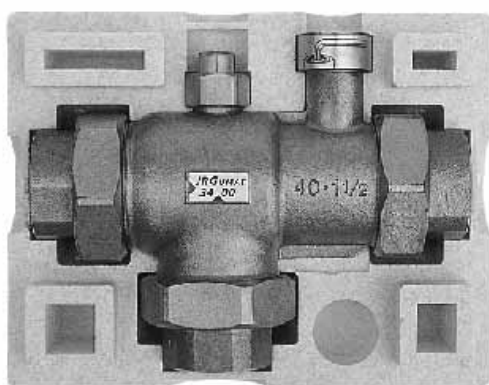

The transport packaging of every JRGUMAT® thermoblending valve is used as thermal insulation following installation and adjustment.

E

Function

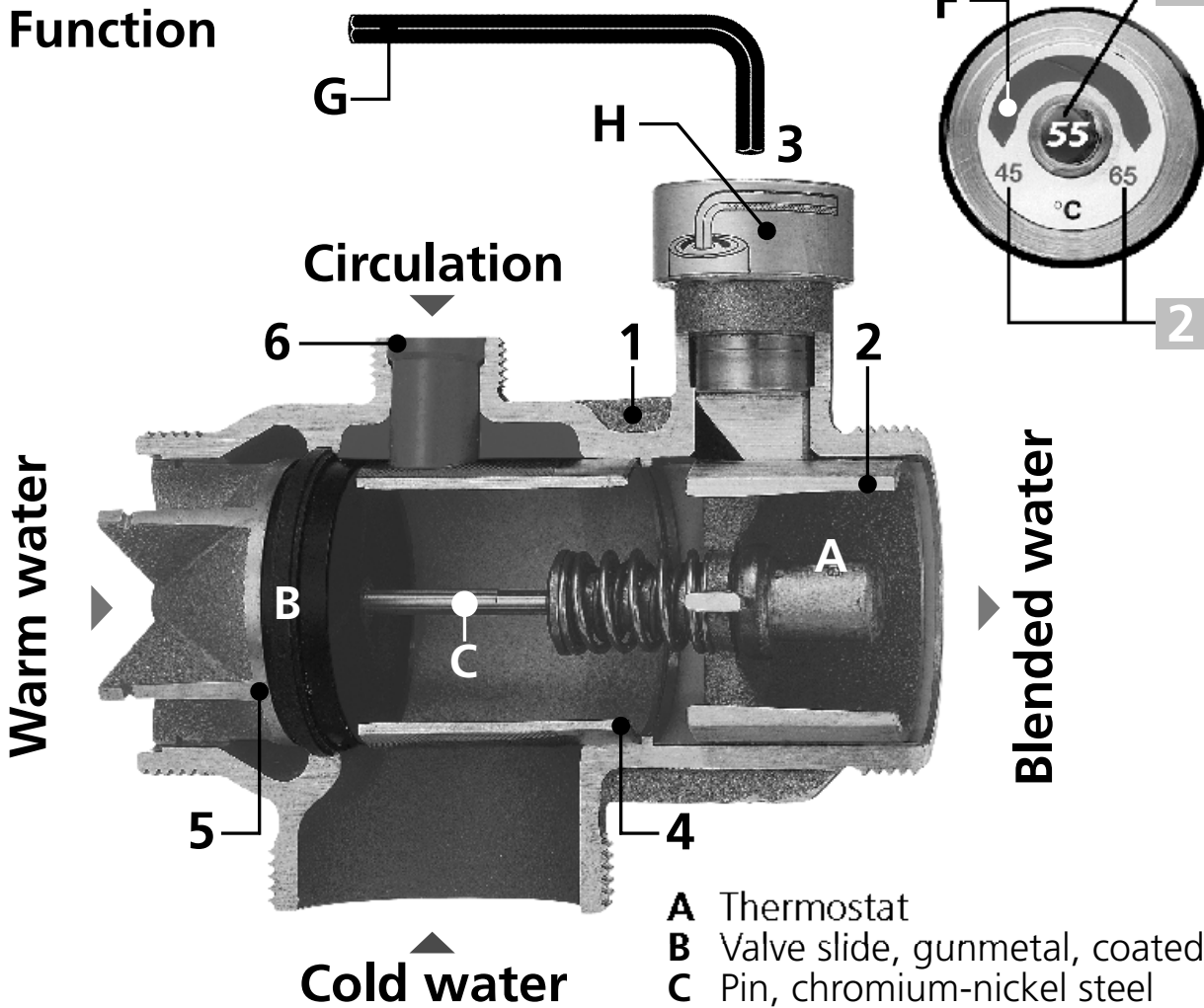

- A** Thermostat
- B** Valve slide, gunmetal, coated
- C** Pin, chromium-nickel steel
- 1** Body, gunmetal
- 2** Regulating gate, gunmetal
- 3** Adjusting screw, brass
- 4** Cold water seat, stainless steel
- 5** Hot water seat, gunmetal
- 6** Circulation sleeve, plastic

1 Standard-temperature °C	2 Ranges of adjustment °C	Change in the blended water temperature with 1 full key turn		
		GN 1/2-1 DN 15-25	GN 1 1/4-2 DN 32-50	DN 65/80
25	20-30	ca. 6 K	ca. 4 K	ca. 2 K
40	30-45			
48	36-53			
55	45-65			

Factory setting/Changing

JRGUMAT® thermoblending valves are fitted with a thermostat allocated to a standard temperature and set to a standard temperature at the factory.

This is apparent from the article number, it appears in the centre of the temperature label **F** and is indicated on the packaging. A change in standard temperature can only be made within the limits of the blended water adjustment range allocated. Proceed as follows: Pierce the middle of the temperature label **F** with the Allen key **G**. Turning the screw **H** clockwise will increase the blended water temperature while turning the key counterclockwise will lower it. The flow rate must be in the hatched field “Nominal value tolerance $\pm 1K$ ” (q.v. nomogramme).

If the mixing valve is installed in a circulation network, the circulation must be adjusted separately at “zero removal”. To do this, the overall flow rate of the pump (100%) must be adjusted first. Then set the flow rates, which lead to the mixing valve and set the proportion required to cover heat loss on the water heater.

A well-regulated circulation keeps the desired blended water temperature constant even if no blended water is drawn off.

E

Typical blended water installations

DIN	Text	JRG No.	SIA
—	TWK – cold water – WKR		—
—	TWW – hot water – WWV		— —
—	TWZ – WW circulation – WWR		— . .
—	TWM – blended water – WMV		— . .
—	WMZ – WM circulation – WMR	
●	JRGUMAT [®] thermoblend. valve	3400	●
⊗	Shut-off valve	5200-34	⊗
▶	Non-return valve	1610-15	▶
⊗	Backflow preventer with shut-off	5262-81	⊗
◻	Swing check valve	1682	◻
⚙	Safety valve	1020-30	⚙
⊗	Adjusting socket	6310	⊗
⊗	JRGUTHERM [®] circul. flow regul.	320	⊗
⊙	Pump		⊙
⊗←	Drain valve	6000-12	⊗←

Without circulation with separ. hot water outlet

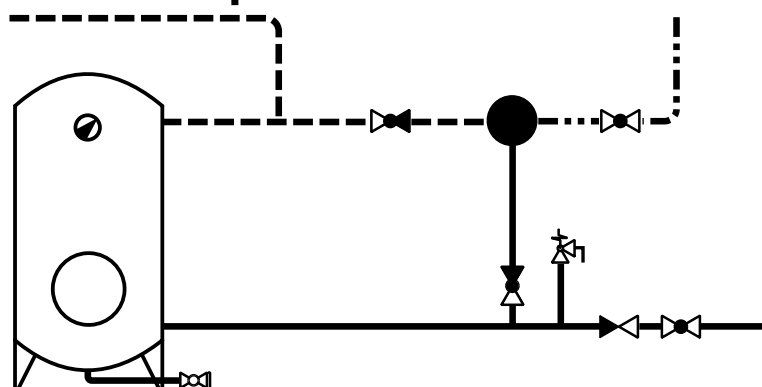

With circulation and hot water outlet

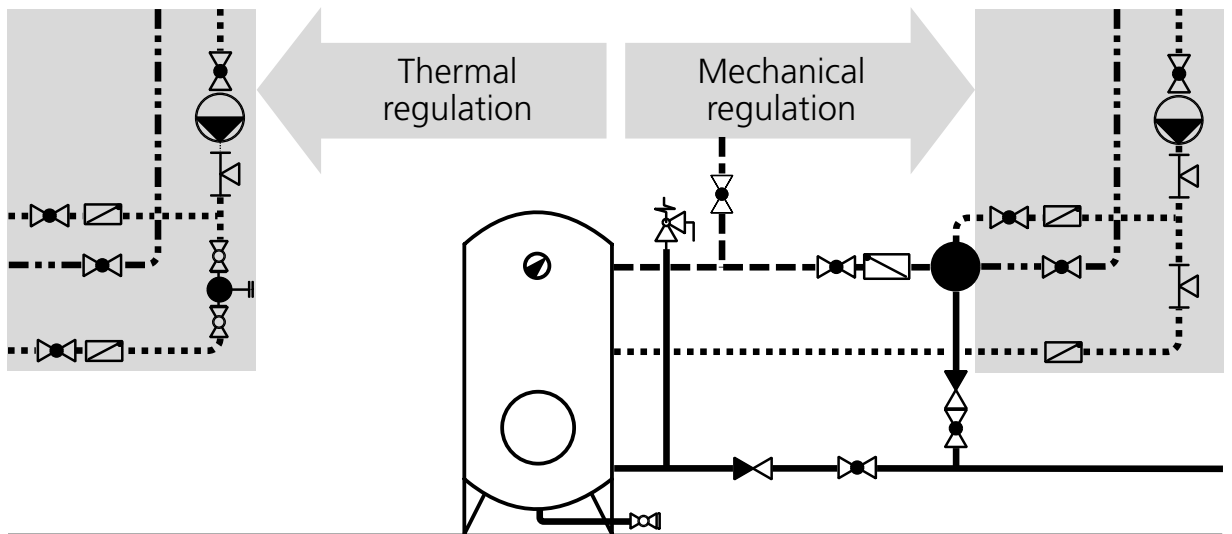

With circulation and thermal disinfection

- Note: To be able to guarantee thermal disinfection, water must pass through every connection or every connection must be flushed.
- Note: Enough hot water must be available for thermal disinfection.



Danger of scalding
Anti-scald protection
is deactivated during
disinfection!

Thermal disinfection only
with JRG LegioTherm® 2T,
JRG 3600 possible.

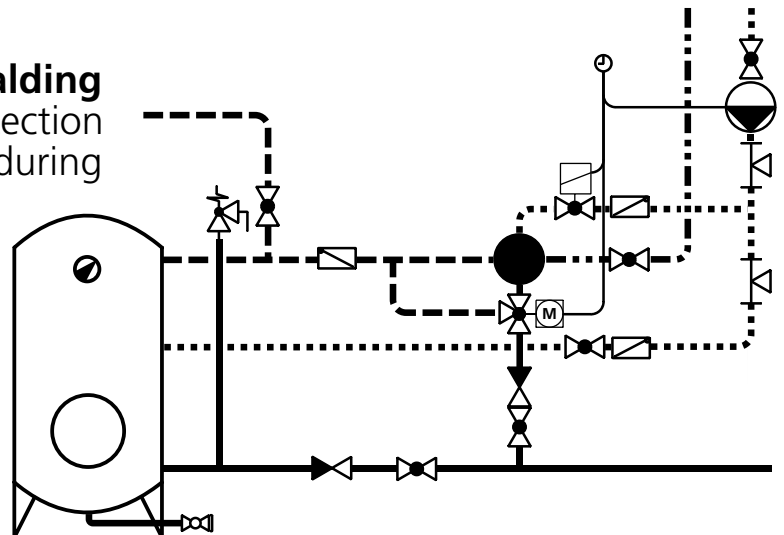

Regulator for hot-water storage tank

- Cold water inflow
- Hot water inflow
- Blend. water outflow
- Circulation inflow,
closed

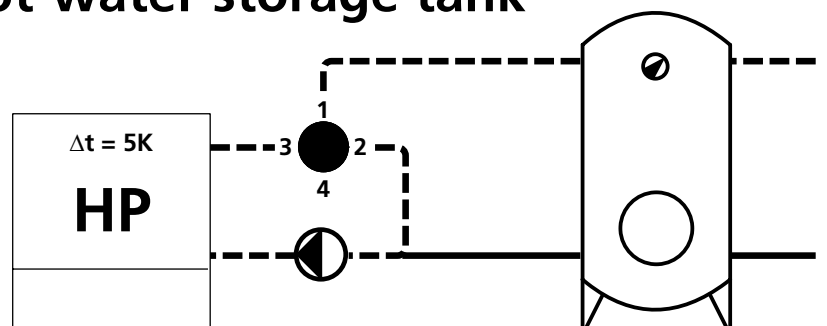

E

Commissioning

The pipes must be flushed thoroughly before commissioning a JRGUMAT[®] thermoblending valve. When the installation is commissioned, the mixing valve is ready for use.

Maintenance

JRGUMAT[®] thermoblending valves require no maintenance. No attempts should be made to repair JRGUMAT[®] thermoblending valves.

Malfunctions

If your JRGUMAT[®] thermoblending valve malfunctions at any time, please contact your plumber.

Compare the installation with the examples. Check whether the required blended water temperature is not attained when enough is removed or whether the temperature fluctuates when idle. In this case, the circulation has not been adequately adjusted.



Unions/Gaskets

JRGUMAT[®] thermoblending valves may only be connected using flat-sealing, genuine JRG unions/gaskets.

AFM 34 seals may not be lubricated with oil or grease.

Questions?

For questions and application-related requests for information, please apply to our technical advisors or to the technical after-sales service.

6320



JRGUTHERM[®]
circulation
flow regulator

3500/3510



JRGUMAT[®]
compact
blending
facility

3600



JRG LegioTherm[®] 2T
circulation flow regulator

Detailed documentations available on request.

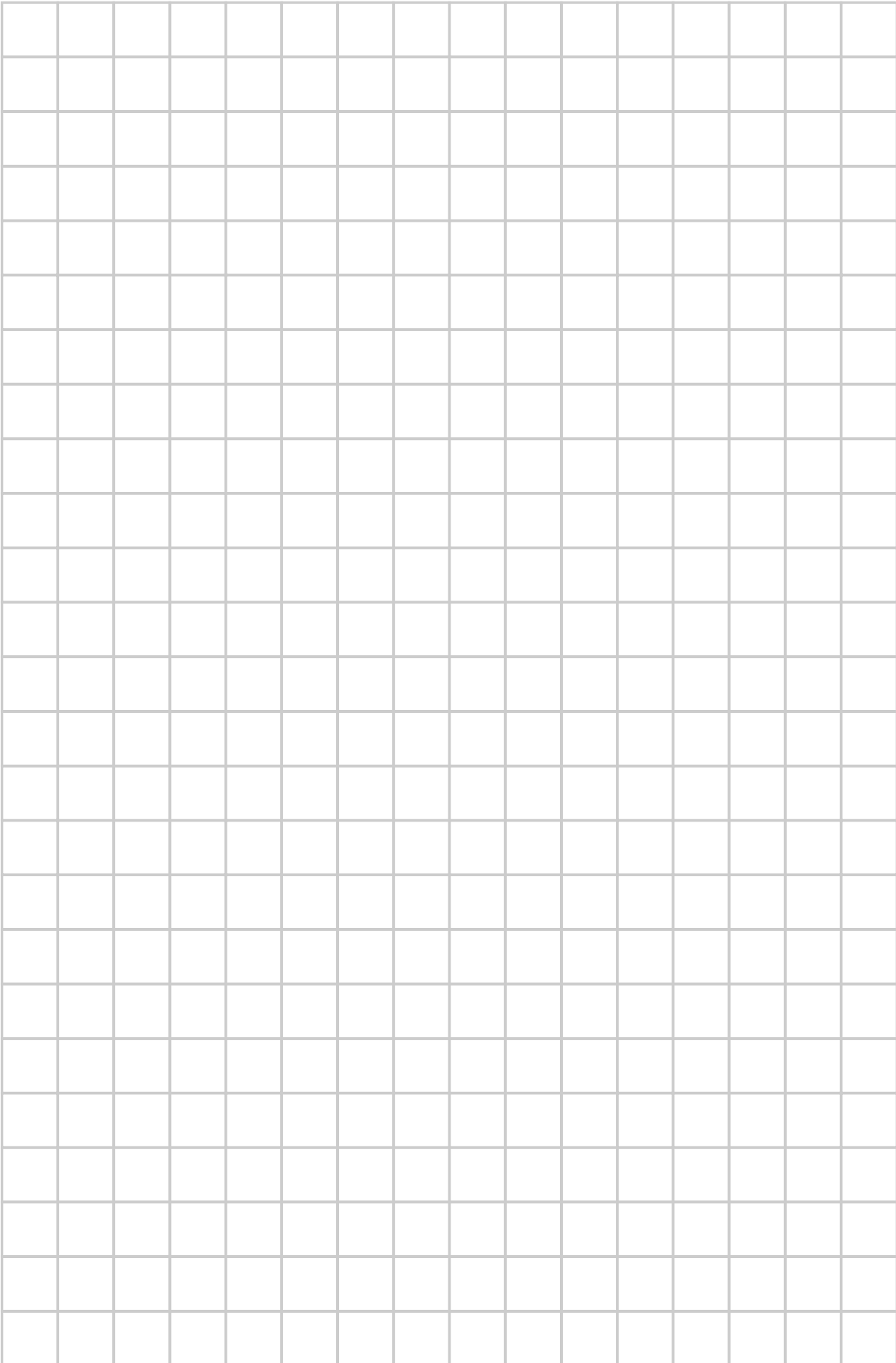

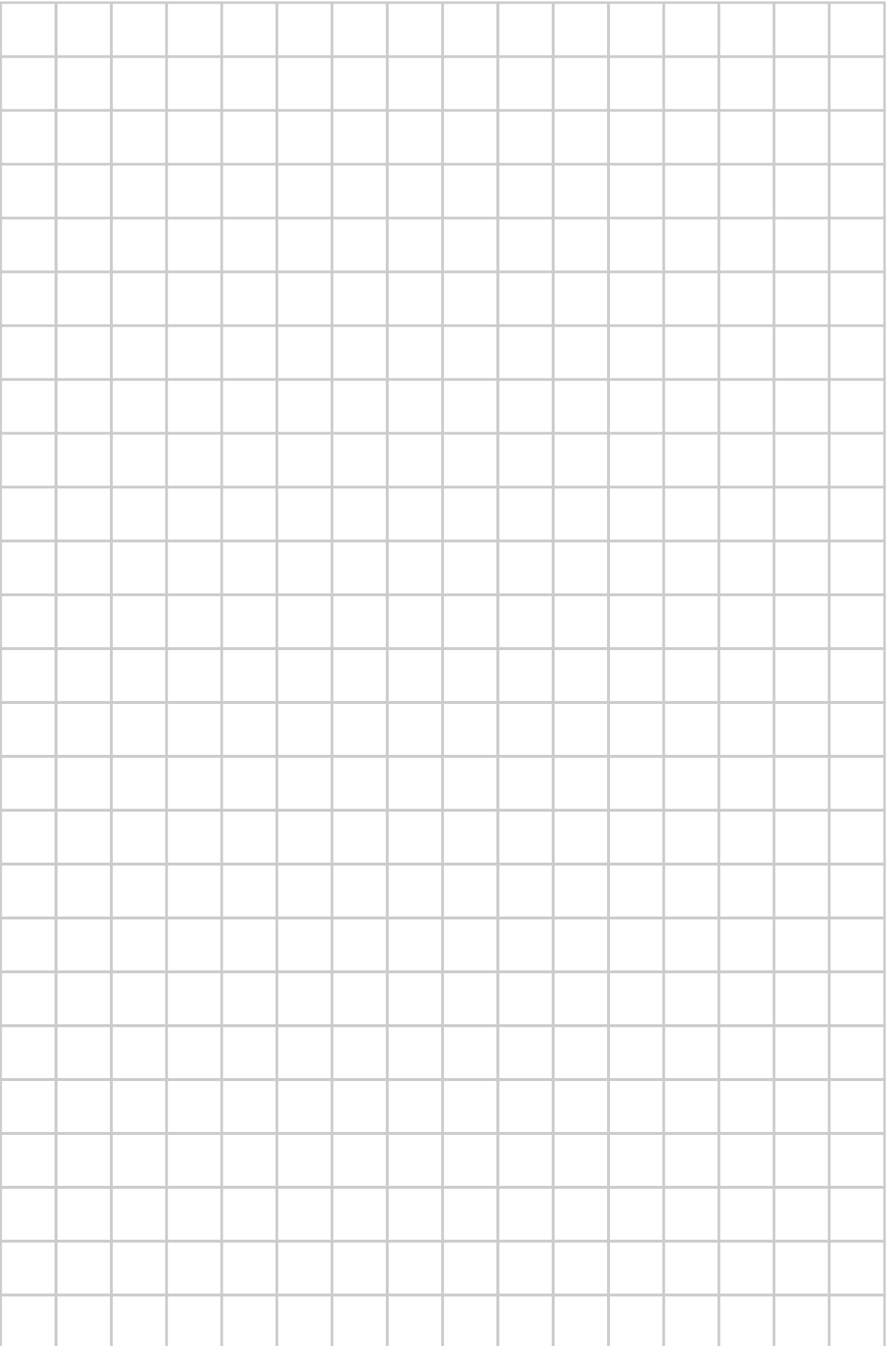

JRG Gunzenhauser AG

CH-4450 Sissach

Hauptstrasse 130
Telefon 061 975 22 22
Telefax 061 975 22 00
www.jrg.ch
info@jrg.ch

JRG

Südschweiz

JRG Gunzenhauser SA
Via Boscioro 20
CH-6962 Viganello/Lugano
Telefon 091 972 26 26
Telefax 091 972 26 27

Deutschland

JRG Gunzenhauser GmbH
Nördliche Grünauerstrasse 65
D-86633 Neuburg/Donau
Telefon (08431) 5817 -0
Telefax (08431)5817 -20
www.jrg.de
info@jrg.de

Österreich

JRG Gunzenhauser GmbH
Stadlauer Strasse 39A
A-1220 Wien
Telefon (01) 310 39 98-0
Telefax (01) 310 39 98-75
www.jrg.at
info@jrg.at

Einbaudatum: Date de montage: Anno d'installazione: Built-in date:

Ihr Installateur: Votre installateur: Il vostro installatore: Your plumber: