

Operating and Installation Instructions

Straight-through blow-down valves - STEVI®BBD 415

DN 25 - 50

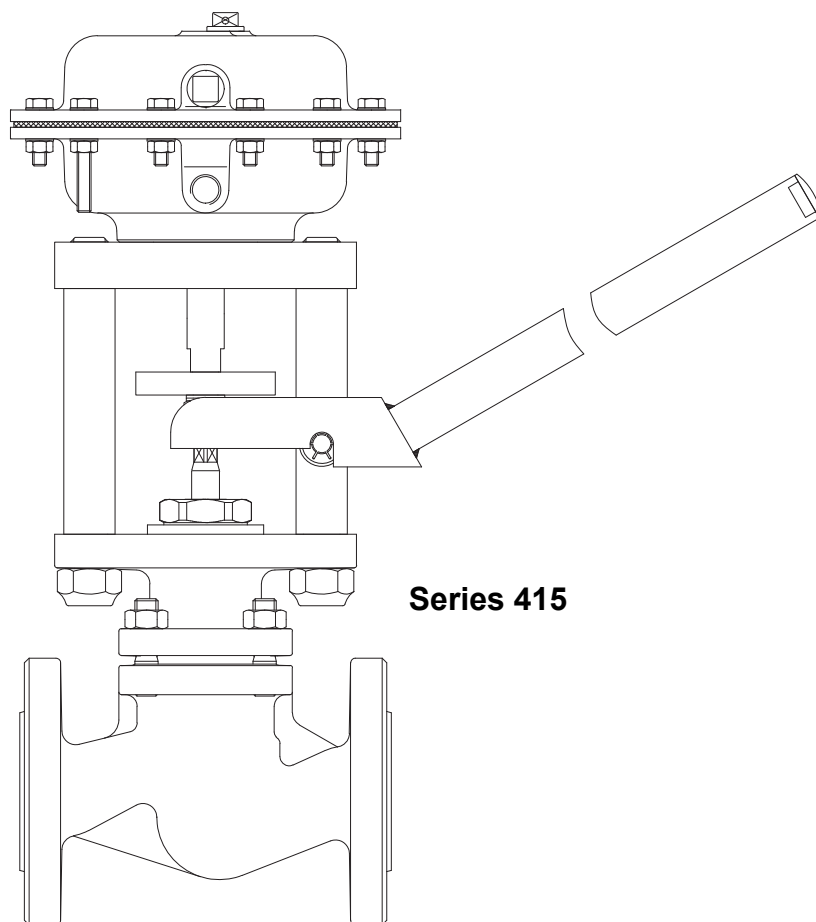

Contents

1.0 General information about these Operating Instructions	2-2	7.3 Replacing the rolling diaphragm and springs	2-11
2.0 Notes on possible dangers	2-2	7.4 Replacing the actuator stem seals	2-13
2.1 Meanings of the symbols used.....	2-2	7.5 Assembling the valve and the actuator	2-13
2.2 Explanatory notes on safety information	2-2	7.6 Retrofitting the hand lever	2-13
3.0 Storage and transport	2-2	7.7 Tightening torques.....	2-14
4.0 Description	2-3	7.7.1 Tightening torques for hexagon nuts	2-14
4.1 Applications.....	2-3	7.7.2 Tightening torques for flange nuts	2-14
4.2 Operating principle	2-3	7.7.3 Tightening torques for studs	2-14
4.3 Diagrams	2-4	8.0 Troubleshooting	2-14
4.4 Technical data	2-6	9.0 Troubleshooting table	2-15
4.5 Marking	2-6	10.0 Dismantling the valve	2-16
5.0 Installation	2-7	10.1 Dismantling the actuator from the valve	2-16
5.1 General notes on installation.....	2-7	10.2 Dismantling the actuator.....	2-16
6.0 Putting the valve into operation	2-8	11.0 Warranty / Guarantee	2-17
7.0 Care and maintenance	2-9		
7.1 Replacing the valve stem seals.....	2-9		
7.1.1 PTFE V-ring unit design	2-9		
7.2 Replacing the valve trim.....	2-10		

1.0 General information about these Operating Instructions

These Operating Instructions provide information on mounting and maintaining the valves. Please contact the supplier or the manufacturer in case of problems which cannot be solved by reference to the Operating Instructions.

They are binding for transport, storage, installation, start-up, operation, maintenance and repair.

The notes and warnings must be observed and adhered to at all times.

- Handling and all work must be carried out by expert personnel or all activities supervised and checked by a suitably trained person.

It is the duty of the operator to define areas of responsibility and competence and to supervise personnel.

- All currently valid local safety requirements must be additionally applied and observed when removing the valves from service or when maintaining or repairing them.

The manufacturer reserves the right to introduce technical modifications at any time.

These Operating Instructions comply with the requirements of the relevant EU Directives.

2.0 Notes on possible dangers

2.1 Meanings of the symbols used



Warning regarding a general danger.

2.2 Explanatory notes on safety information

Dangers, risks and safety information are highlighted in these Operating and Installation Instructions to attract the reader's attention.

Information marked with the above symbol and "**ATTENTION !**" describes behaviour or procedures which - if ignored - can result in serious or fatal injury to users or third parties or in material damage to the system or the environment. The behaviour and procedures referred to must be complied with and suitable measures implemented to monitor such compliance.

All other information not specifically emphasised, such as transport, installation, operating and maintenance instructions as well as technical data (in these Operating Instructions, in the product documentation or on the device itself) must likewise be complied with in order to avoid faults which could directly or indirectly cause serious injury to persons or damage to property.

3.0 Storage and transport

	<p>ATTENTION !</p> <ul style="list-style-type: none">- Protect against external shocks (impact, vibration, etc.).- Valve mountings such as actuators, handwheels, bonnets, etc. must not be used to absorb external forces, e.g. they are not designed to be used as climbing aids or as attachment points for lifting gear.- Suitable handling and lifting equipment must always be used. Refer to the data sheet for weights.
---	--

- Permissible temperature range: -20°C to +65°C.

- The paint is a base coat to protect against corrosion during transport and storage. Be careful not to damage the paint protection.

4.0 Description

4.1 Applications

Blow-down valves are used to "blow down steam boilers".



ATTENTION !

- Refer to the data sheet for applications, limits of use and operating options.
- Certain media require or preclude the use of special materials.
- The valves are designed for standard operating conditions. If the actual conditions exceed these requirements, e.g. aggressive or abrasive media, all non-standard requirements should be indicated in the order.

All information provided here conforms to the Pressure Equipment Directive 2014/68/EU. It is the responsibility of the machine planner to ensure compliance.

Special markings on the valve must be taken into account.

Refer to the data sheet to see which materials are used in standard versions.

Please contact the supplier or the manufacturer if you have any questions.

4.2 Operating principle

The blow-down valves are specially designed for blowing down steam boilers with compressed air. When opened for a short period by a pneumatic actuator or manually operated with a lever, they form an eddy of water that entrains sludge from the boiler end. Corrosion is effectively prevented.

The flow always approaches a blow-down valve in the closing direction. The closing force of the springs is supported by the medium pressure.

4.3 Diagrams

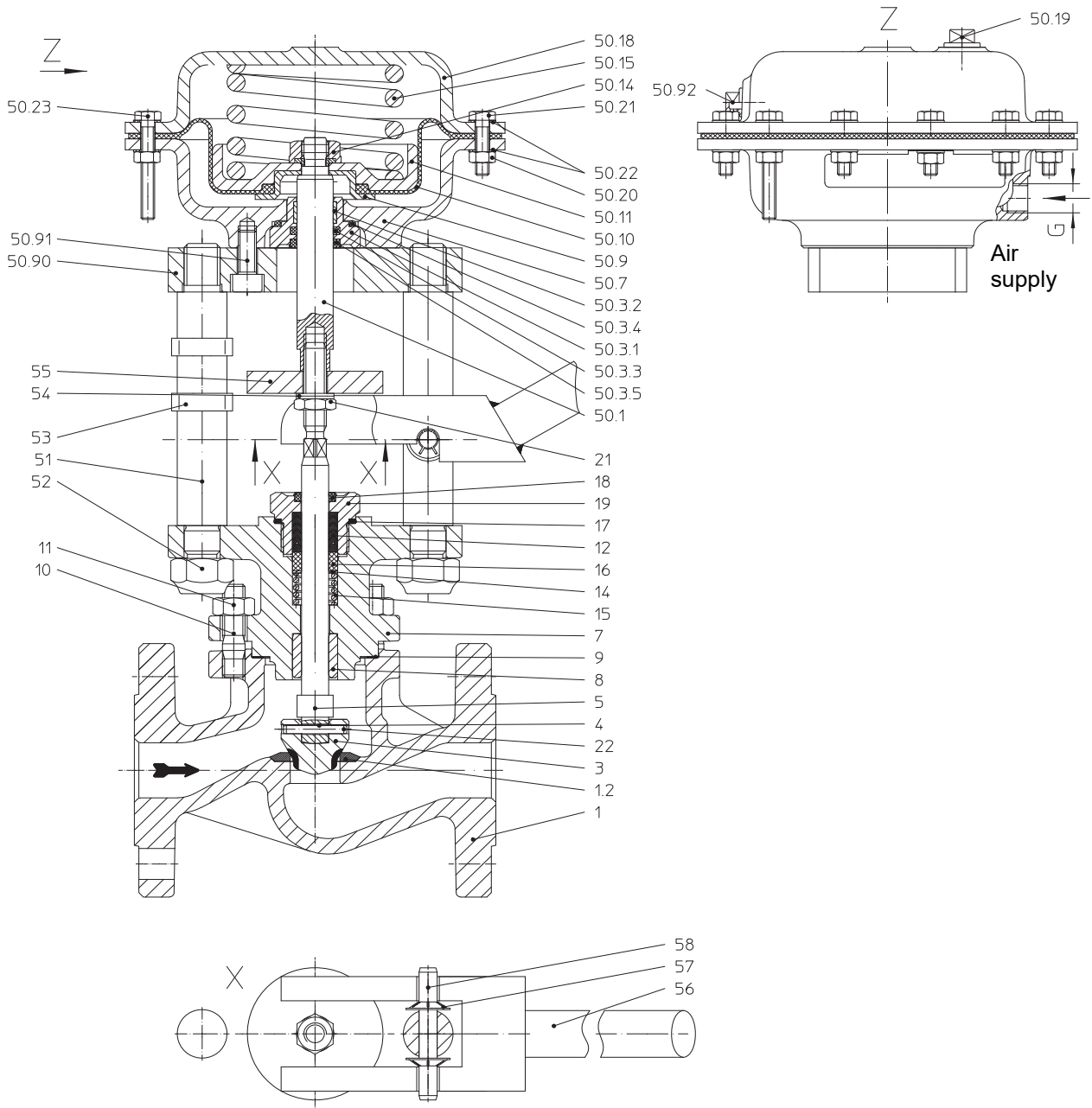

Fig. 1: Series 415 DN 25, 32

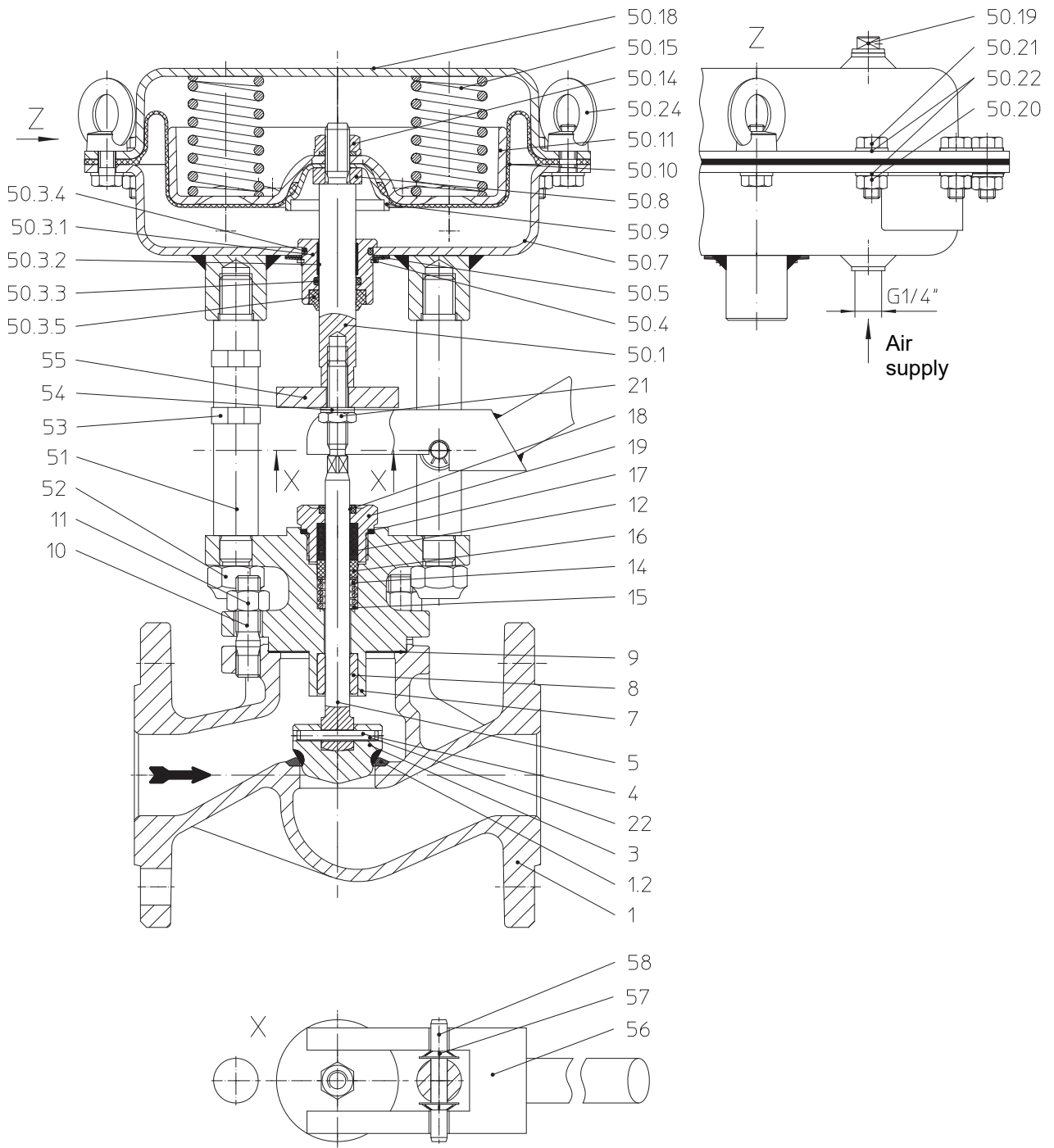

Fig. 2: Series 415 DN 40, 50

4.4 Technical data

For

- Principal dimensions,
- Pressure-temperature ratings, etc. refer to the data sheet.

4.5 Marking

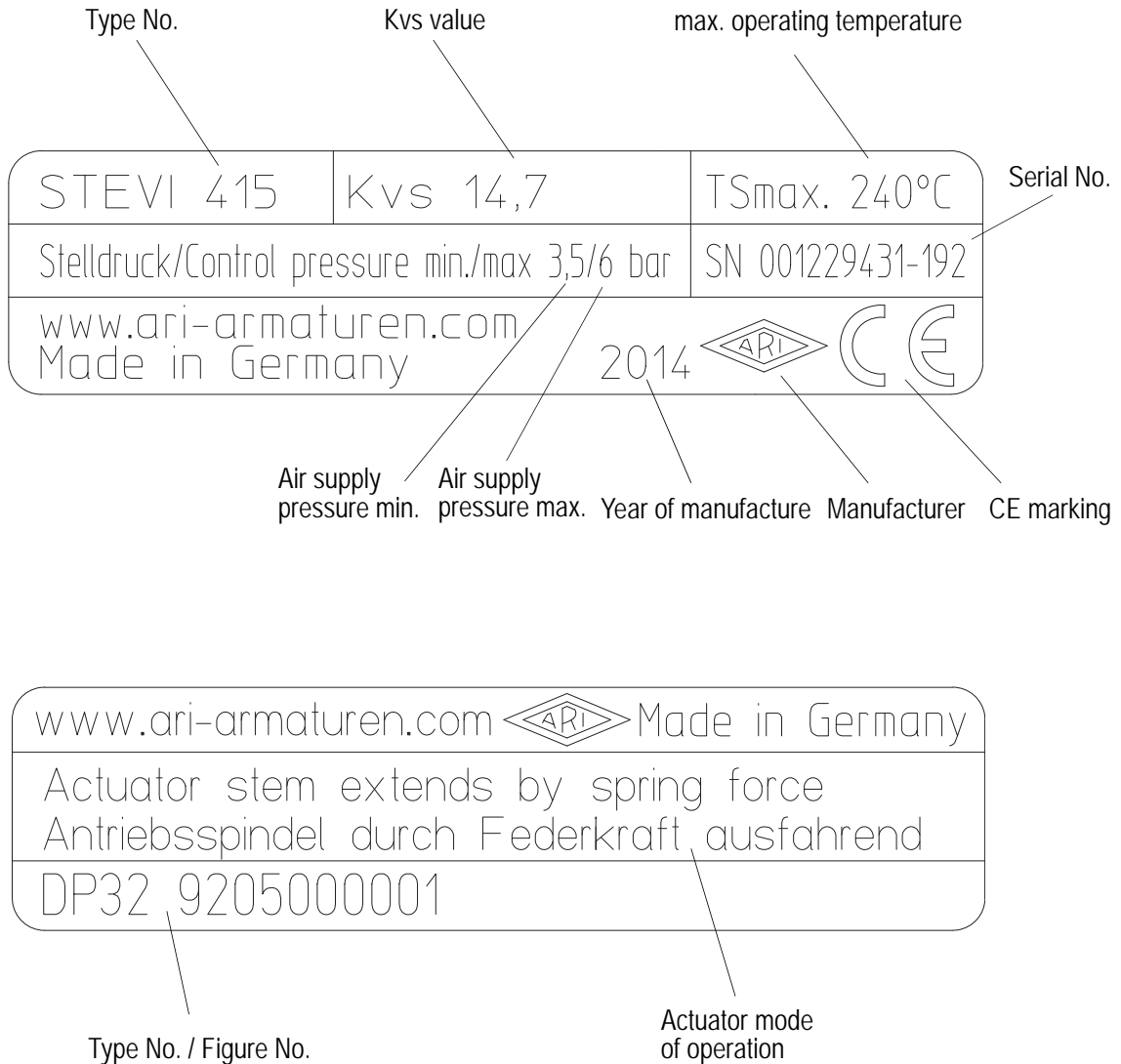

Fig. 3

Address of manufacturer: refer to item 11.0 Warranty / Guarantee

According to the Pressure Equipment Directive (fluid group 2, diagram 7, annex II), valves are only allowed to bear the CE marking upwards of PN 40 ≥ DN 40.

5.0 Installation

5.1 General notes on installation

The following points should be taken into account in addition to the general principles governing installation work:



ATTENTION !

- No water in the pipeline when blow down
- Remove flange covers if present.
- The interior of the valve and pipeline must be free from foreign particles.
- Note the installation position in relation to the flow (see mark on valve).
- When installing the valve, allow a sufficient clearance to retrofit the hand lever for emergency operation.
- Steam line systems should be designed to prevent water accumulation (alternatively, the pipeline should be drained prior to blowing down the boiler).
- The following four requirements need to be met: The pipeline behind the blow down valve needs to be sloping downwards, its diameter needs to gradually increase in size, there must not be any obstruction thus ensuring free flow (no check valve directly behind the blow down valve) and lastly the pipeline's turning radius needs to be large.
- Lay pipelines so that damaging shear, bending or torsional forces are avoided.
- The pipeline between the boiler and the blow-down valve should not be more than two metres long.
- Protect valves from dirt during construction work.
- Connection flanges must mate exactly.
- Connecting bolts for pipe flanges should be mounted preferably from the counter flange side (hexagon nuts from the valve side).
 At DN15-32: If valves should be mounted directly to valves, the upper flange connecting bolts should be preferably executed with studs and hexagon nuts on both sides.
- Valve mountings such as actuators, handwheels, bonnets, etc. must not be used to absorb external forces, e.g. they are not designed to be used as climbing aids or as attachment points for lifting gear.
- Suitable handling and lifting equipment must always be used when installing the valve.
 Refer to the data sheet for weights.
- Keep the thread and shaft of the stem free from paint.
- Centre the gaskets between the flanges.
- Observe the information provided in the Operating Instructions for the various accessories (e.g. the solenoid valve).
- The valve should be installed complete with the crossbar.
- Choose the optimum line cross-section according to the available driving power and line length.
- The technical data of the actuator unit must be compatible with the operating requirements.
- The control pressure must match the information given on the rating plate of the actuator unit.
- Air supply acc. to DIN IEC 60654-2.
- Water free from dirt and corrosives, max. temperature +80°C

- *The complete actuator unit must be mounted on the valve, including the distance columns and coupling parts provided for this purpose.*
- *All persons charged with installing compressed air systems must be familiar with the applicable rules and regulations.*

- The planner / construction company or operator is responsible for positioning and installing the products.
- The valves are designed for application, not influenced from weather.
- For application outside or in adverse environments like corrosion-promoting conditions (sea water, chemical vapours, etc.), special constructions or protective measures are recommended.

6.0 Putting the valve into operation



ATTENTION !

- *Before putting the valve into operation, check the material, pressure, temperature and direction of flow.*
- *All local safety instructions must be observed.*
- *Residues in piping or valves (dirt, weld beads, etc.) inevitably lead to leakage and/or damage.*
- *Touching the valve when it is operating at high (> 50°C) or low (< 0°C) media temperatures can cause injury.*
Affix a warning notice or provide protective insulation as appropriate!
- *The actuator can be used in the temperature range from -40°C to +100°C. At temperatures below zero, it is important to ensure that the control air is dry, while at high temperatures insulation against heat should be provided where possible.*

Before putting a new plant into operation or restarting a plant after repair or modification, always make sure that:

- *All work has been completed correctly!*
- *The valve is in the correct position for its function.*
- *The necessary safety devices have been attached.*

7.0 Care and maintenance

Maintenance work and intervals must be defined by the operator according to the service conditions.

7.1 Replacing the valve stem seals

7.1.1 PTFE V-ring unit design

PTFE V-ring unit (pos. 12) consisting of:

- 1 backing ring
- 4 sealing rings
- 1 cover ring

This stem seal is self-adjusting owing to the built-in compression spring (pos. 15). If the stem begins to leak, the seal pack is worn out and must be replaced.

To replace the PTFE V-ring unit:



ATTENTION !
Refer to sections 10.0 and 11.0 before dismantling the valve.

- Remove the actuator (refer to section 10.1).
- When replacing the PTFE V-ring unit (pos. 12), make sure that all parts are installed in the correct order and position (refer to Fig. 4).
- The gasket (pos. 17) must be replaced.

Note:

Damaged stems must also be replaced (refer to section 7.2 for instructions) because a new seal pack will soon begin to leak again if the stem is no longer intact.

- To assemble the actuator, refer to section 7.5.

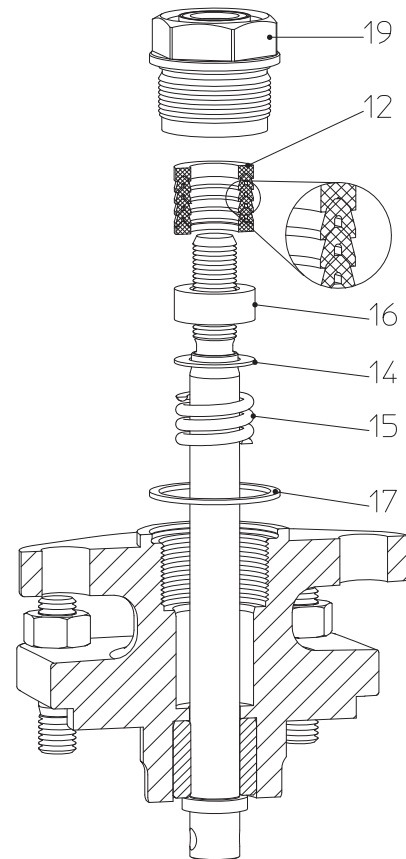

Fig. 4: PTFE V-ring unit

7.2 Replacing the valve trim



ATTENTION!

Refer to sections 10.0 and 11.0 before dismantling the valve.

- Remove the actuator (refer to section 10.1).
- Loosen the nuts (pos. 11).
- Detach the mounting bonnet (pos. 7).
- Slacken the screw joint (pos. 19) approximately 1 turn.
- Extract the plug (pos. 3) and stem (pos. 5).
- Drive the pins (pos. 4, 22) out with a drift.
- Bore new parts.
- Center locking pins (pos. 4, 22) and drive it as pin-combination into the bore hole.
- Replace the flat gasket (pos. 9).
- Assemble in reverse order.
- Secure with the nuts (pos. 11) and tighten crosswise (for tightening torques refer to section 7.7).
- To assemble the actuator, refer to section 7.5.

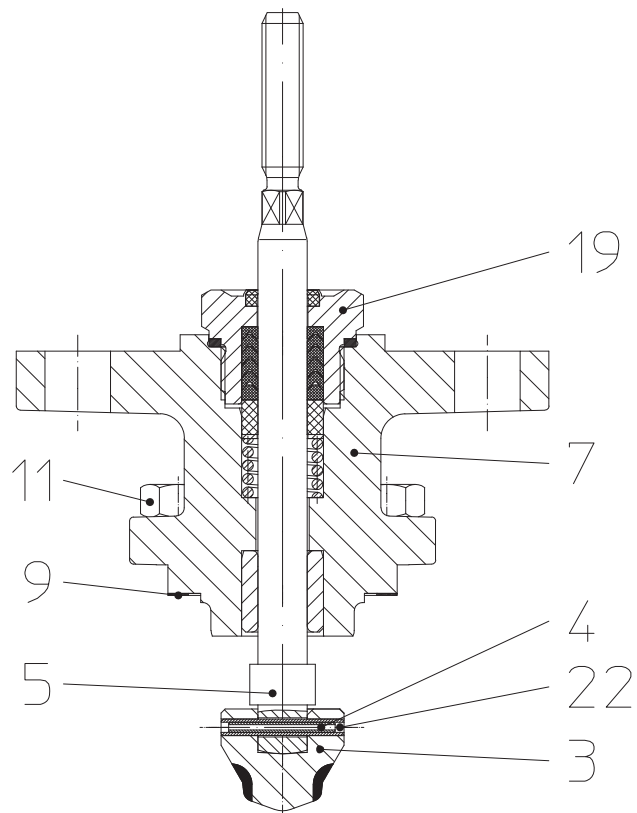

Fig. 5

7.3 Replacing the rolling diaphragm and springs



ATTENTION !

Refer to sections 10.0 and 11.0 before dismantling the valve.

- If the rolling diaphragm is replaced, the springs must be replaced at the same time.

- Remove the actuator (refer to section 10.1).
- Dismantle the actuator (refer to section 10.2).
- Remove the following units: stem (pos. 50.1) / diaphragm plate (pos. 50.11) / rolling diaphragm (pos. 50.10) / diaphragm flange (pos. 50.9).
- Loosen the flange nut (pos. 50.14).
- Remove the diaphragm flange (pos. 50.9).
- Replace the rolling diaphragm (pos. 50.10) and reassemble.

Note:

When this unit is assembled, a hole must be bored in the rolling diaphragm (pos. 50.10) and aligned with the camber of the diaphragm plate (pos. 50.11) as well as with the flat of the stem.

- Insert the unit into the actuator.
- The camber of the diaphragm plate (pos. 50.11) that is aligned with the hole in the rolling diaphragm (pos. 50.10) must also be exactly positioned over the air connection in the diaphragm base (pos. 50.7) (Fig. 6 and Fig. 7).

Note:

The flat of the stem (pos. 50.1) should still be easily accessible after the valve and actuator have been assembled (Fig. 6 and Fig. 7).

- Align the compression springs (pos. 50.15) centrally on the diaphragm plate (pos. 50.11).
- Make sure the compression springs are properly positioned!
- Fit the diaphragm cover (pos. 50.18) over the springs (pos. 50.15) and screw together (for tightening torques refer to section 7.7).
- To assemble the actuator, refer to section 7.5.

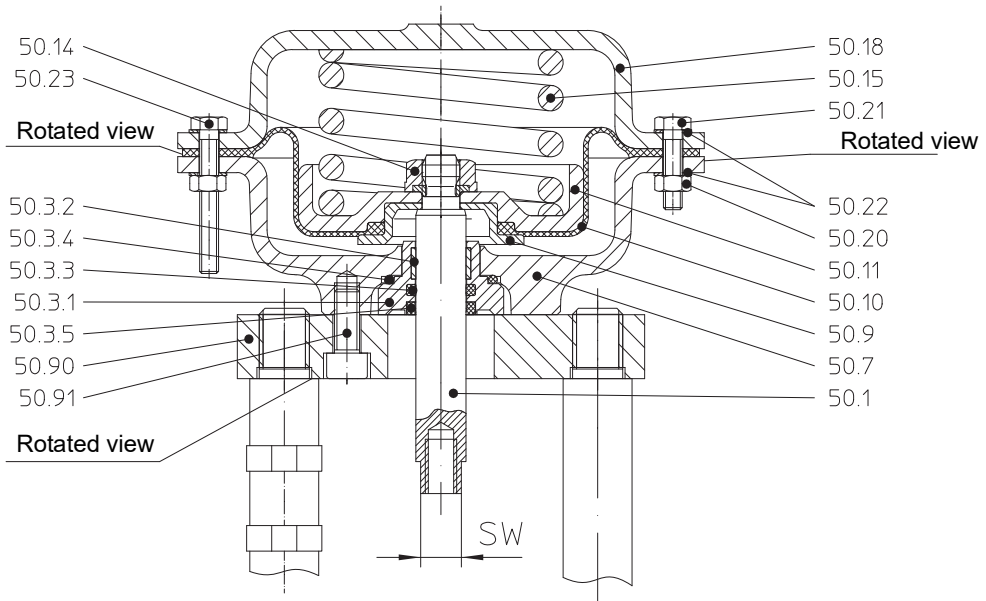

Fig. 6: Actuator for DN 25, 32

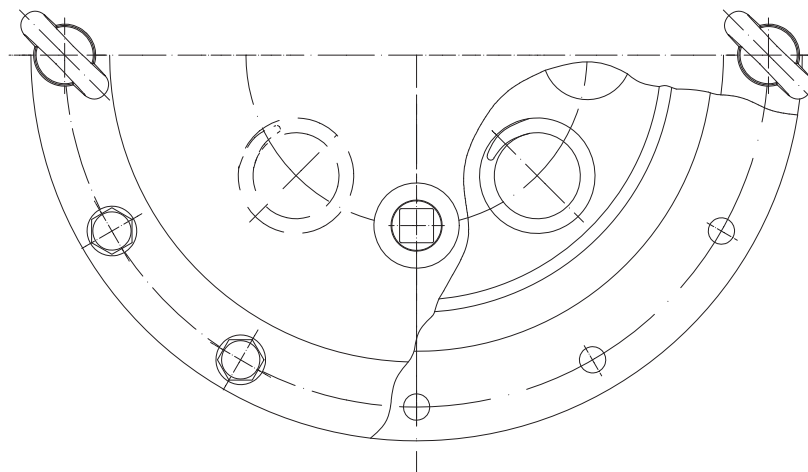
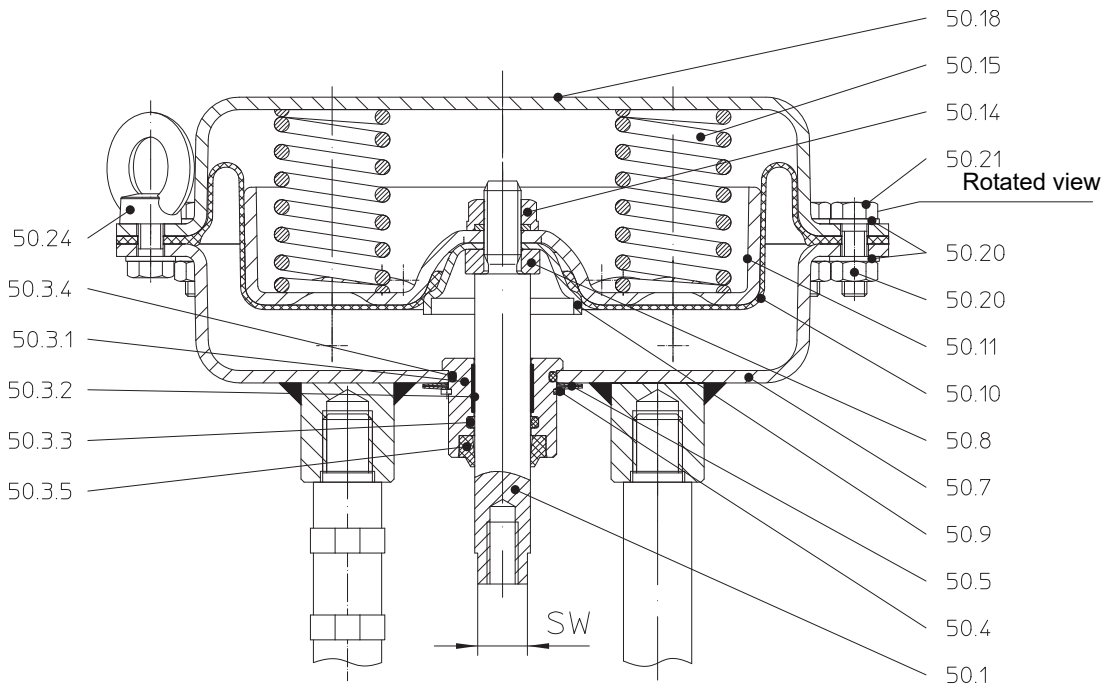

Fig. 7: Actuator for DN 40, 50

7.4 Replacing the actuator stem seals



ATTENTION !

Refer to sections 10.0 and 11.0 before dismantling the valve.

- Remove the actuator (refer to section 10.1).

DN 25:

- Unscrew the socket cap screws (pos. 50.91).
- Remove the flange (pos. 50.90).
- Extract the complete stem guide (pos. 50.3).
- Replace the O-rings (nos. 50.3.3 and 50.3.4), the scraper (pos. 50.3.5) and/or the guide strip (pos. 50.3.2).
- Assemble in reverse order (for tightening torques refer to section 7.7).

DN 40, 50:

- Dismantle the actuator (refer to section 10.2).
- Remove the retaining rings (pos. 50.4) and the disc springs (pos. 50.5).
- Extract the stem guide (pos. 50.3.1).
- Replace the O-rings (nos. 50.3.3 and 50.3.4), the scraper (pos. 50.3.5) and/or the guide strip (pos. 50.3.2).
- Assemble in reverse order (for tightening torques refer to section 7.7).

- To assemble the actuator, refer to section 7.5.

7.5 Assembling the valve and the actuator

- Screw the lock nut (pos. 21) downwards on the valve stem (pos. 5).
- Position the two lock washers (pos. 54) and the travel indicator (pos. 55) on the lock nut.
- Apply 6 bar control air pressure to the actuator.
- Mount the actuator on the valve.
- Fasten it with the nuts (pos. 52).
- Screw the valve stem (pos. 5) into the actuator stem (pos. 50.1).
- Reduce the control air pressure to the final signal.

DN 25 = 2.5 bar

DN 32 = 2.4 bar

DN 40 = 2.4 bar

DN 50 = 2.4 bar

- Screw the valve stem (pos. 5) upwards inside the valve as far as the stop.



ATTENTION !

- The actuator stem (pos. 50.1) must not be pulled down.

- Lock with the nut (pos. 21) (for tightening torques refer to section 7.7).

7.6 Retrofitting the hand lever

- The hand lever can be retrofitted at any time.
- The locked straight pin (pos. 58) is mounted over the valve output and included in the scope of supply.
- Slide the fork head of the lever (pos. 56) over the straight pin (pos. 58) and under the travel indicator (pos. 55).

7.7 Tightening torques

7.7.1 Tightening torques for hexagon nuts

(pos. 11)

M 10 = 15-30 Nm

M 12 = 35-50 Nm

(pos. 21)

M 12 = 50 Nm

7.7.2 Tightening torques for flange nuts

(pos. 50.14)

M 12 = 50 Nm

7.7.3 Tightening torques for studs

(pos. 50.21)

M 6 = 7 Nm

M 8 = 5 Nm

8.0 Troubleshooting

In the event of a malfunction or faulty operating performance, check that all installation and adjustment work has been carried out and completed in accordance with these Operating Instructions.



ATTENTION !

- The safety regulations must be observed at all times during troubleshooting.

If you cannot correct the fault with the help of the table in section "9.0 Troubleshooting table", please consult the supplier or manufacturer.

9.0 Troubleshooting table

 **ATTENTION !**

- Read sections 10.0 and 11.0 prior to all dismantling or repair work!
- Read section 6.0 before restarting the plant!

Fault	Possible cause	Corrective measure
No flow	Valve closed.	Open valve (using actuator).
	Flange covers not removed.	Remove flange covers.
Little flow	Valve not sufficiently open.	Open valve (using actuator).
	Piping system clogged.	Check piping system.
Valve stem moves in jerks	Stuffing box seal too tight (valves with graphite packing).	Slacken screw joint (pos. 29) slightly; valve must not begin to leak.
Valve stem leaking	PTFE V-ring unit damaged or worn.	Replace seal pack (pos. 12); refer to section 7.1.1.
	Screw joint (pos. 29) is not tight (valves with stuffing box packing).	Tighten screw joint (pos. 29) and replace packing if necessary.
Leakage too high when valve closed	Sealing surfaces of plug eroded or worn.	Replace plug; refer to section 7.2.
	Sealing edge of seating damaged or worn.	Grind seat.
	Seating and/or plug dirty.	Clean valve trim.
	Pneumatic actuator not completely vented; spring force not fully effective.	Vent actuator air chamber completely.
	Actuator not powerful enough.	Install more powerful actuator.
Actuator unit does not move	No compressed air on control pressure line.	Identify causes and take remedial action.
	Actuator unit incorrectly installed.	Check actuator mode of operation and connect to control pressure line accordingly.
	Rolling diaphragm defective.	Replace rolling diaphragm and springs.
Not enough positioning force	Stem seal is leaking.	Replace stem seal.
	Vent is clogged and air cannot escape from actuator.	Screw plug must be unclogged.
	Actuator not completely vented.	Check controller adjustment.

10.0 Dismantling the valve



ATTENTION !

Check the following points carefully:

- The piping system must be pressureless.
- The medium must be cool.
- The plant must be drained.
- The piping system must be purged of all caustic, inflammable, aggressive or toxic media.

10.1 Dismantling the actuator from the valve

- Move the actuator into the upper travel position with control air pressure.
- Loosen the lock nut (pos. 21).
- Unscrew the valve stem (pos. 5) from the actuator stem (pos. 50.1).
- Loosen the fastening nuts (pos. 52).
- Dismantle the actuator from the valve.

10.2 Dismantling the actuator

- Reduce the control air pressure to "0" and disconnect the control air line from the compressed air system.
- Loosen the screws (pos. 50.21) on the actuator and remove the diaphragm cover (pos. 50.18).



ATTENTION !

- The longer screws (pos. 50.23) should be loosened last symmetrically in order to reduce the spring pre-tension gradually.
- The order described above must be observed to prevent **injury** to persons.

11.0 Warranty / Guarantee

The extent and period of warranty cover are specified in the "Standard Terms and Conditions of Albert Richter GmbH & Co. KG" valid at the time of delivery or, by way of departure, in the contract of sale itself.

We guarantee freedom of faults in compliance with state-of-the-art technology and the confirmed application.

No warranty claims can be made for any damage caused as the result of incorrect handling or disregard of operating and installation instructions, datasheets and relevant regulations.

This warranty also does not cover any damage which occurs during operation under conditions deviating from those laid down by specifications or other agreements.

Justified complaints will be eliminated by repair carried out by us or by a specialist appointed by us.

No claims will be accepted beyond the scope of this warranty. The right to replacement delivery is excluded.

The warranty shall not cover maintenance work, installation of external parts, design modifications or natural wear.

Any damage incurred during transport should not be reported to us but *rather* to the competent cargo-handling depot, the railway company or carrier company immediately or else claims for replacements from these companies will be invalidated.



Technology for the Future. GERMAN QUALITY VALVES

ARI-Armaturen Albert Richter GmbH & Co. KG, D-33750 Schloß Holte-Stukenbrock
Telephone (+49 5207) 994-0 Telefax (+49 5207) 994-158 or 159
Internet: <http://www.ari-armaturen.com> E-mail: info.vertrieb@ari-armaturen.com