

Operating and installation instructions

Pressure reducing valve **PREDU[®]**

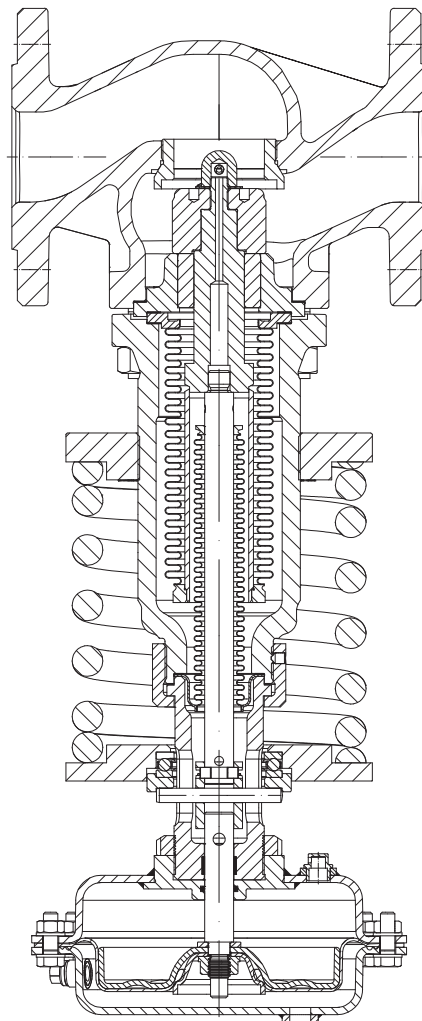

PREDU[®]
(Series 700)

Contents

1.0 General information on operating instructions	2-2	5.5 System arrangement - pressure reducing station	2-11
2.0 Notes on possible dangers	2-2	5.6 Strainer	2-12
2.1 Significance of symbols	2-2	5.7 Safety valves	2-12
2.2 Explanatory notes on safety information	2-2	6.0 Putting the valve into operation	2-12
3.0 Storage and transport	2-3	7.0 Care and maintenance	2-13
4.0 Description	2-3	8.0 Troubleshooting	2-13
4.1 Scope of applications	2-3	9.0 Troubleshooting table	2-14
4.2 Operating principles	2-4	10.0 Dismantling the valve or the top part	2-16
4.3 Diagram	2-5	11.0 Warranty / Guarantee	2-16
4.3.1 Parts	2-6		
4.4 Technical data - remarks	2-6		
4.5 Marking	2-7		
5.0 Installation	2-8		
5.1 General notes on installation	2-8		
5.2 Requirements at the place of installation	2-9		
5.3 Installation instructions concerning actuators	2-9		
5.4 Control line, flow restrictor, water seal pot	2-10		

1.0 General information on operating instructions

These operating instructions provide information on mounting and maintaining the fittings. Please contact the supplier or the manufacturer in case of problems which cannot be solved by reference to the operating instructions.

They are binding on the transport, storage, installation, start-up, operation, maintenance and repair.

The notes and warnings must be observed and adhered to.

- Handling and all work must be carried out by expert personnel or all activities must be supervised and checked.

It is the owner's responsibility to define areas of responsibility and competence and to monitor the personnel.

- In addition, current regional safety requirements must be applied and observed when taking the fittings out of service as well as when maintaining and repairing them.

The manufacturer reserves the right to introduce technical modifications at any time.

These operating instructions comply with the requirements of EU Directives.

2.0 Notes on possible dangers

2.1 Significance of symbols



Warning of general danger.

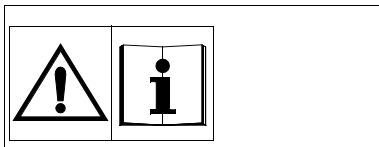

Non-compliance with operating instructions is dangerous!
Read the operating instructions before installation, operation, maintenance or disassembly and adhere to them strictly.

2.2 Explanatory notes on safety information

In these Operating and Installation Instructions dangers, risks and items of safety information are highlighted to attract special attention.

Information marked with the above symbol and "**ATTENTION!**" describe practices, a failure to comply with which can result in serious injury or danger of death for users or third parties or in material damage to the system or the environment. It is vital to comply with these practices and to monitor compliance.

All other information not specifically emphasised such as transport, installation, operating and maintenance instructions as well as technical data (in the operating instructions, product documentation and on the device itself) must also be complied with to the fullest extent in order to avoid faults which in turn can cause serious injury to persons or damage to property.

3.0 Storage and transport



ATTENTION !

- *Protect against external force (like impact, vibration, etc.).*
- *Valve mountings such as actuators, handwheels, hoods must not be used to take external forces, e.g. they are not designed for use as climbing aids, or as connecting points for lifting gear.*
- *Suitable materials handling and lifting equipment should be used.*
See catalog sheet for weights.

- At -20 °C to +65 °C.
- The paint is a base coat to protect against corrosion during transportation and storage. Do not damage paint protection.

4.0 Description

4.1 Scope of applications

Pressure reducing valves are used for „pressure regulation of liquids, steam, gases and vapours in the procedure and process technic as well as in the plant manufacture“.



ATTENTION !

- *Refer to the data sheet for applications, limits on use and possibilities.*
- *The pressure reducing valve is suitable for regulation of fluids of group II acc. to Pressure Equipment Directive 2014/68/EU.*
- *Certain media require or preclude the use of special materials.*
- *The valves are designed for standard operating conditions. If conditions exceed these requirements, e.g. aggressive or abrasive media, the operator should state the higher requirements when ordering.*
- *Valves made from grey cast iron are not authorised for use in systems subject to TRD 110.*

The information complies to the Pressure Equipment Directive 2014/68/EU.

It is the responsibility of the machine planner to ensure compliance.

The special markings on the valve must be taken into account.

Refer to the catalogue sheet to see which materials are used in standard versions.

Please contact the supplier or the manufacturer if you have any questions.

4.2 Operating principles

The pressure reducing valve is a direct acting proportional regulator for regulating the pressure of fluid, gas and vapour media of Fluid Group II pursuant to Pressure Equipment Directive 2014/68/EU. No auxiliary energy is needed.

In a pressureless state the valve is fully open. The media passes through the valve from the inlet to the outlet. The downstream pressure sensing point should be positioned at least 10 x DN or a minimum of 1 m away from the valve, and is passed on to the actuator over the control line pipe (refer to Fig. 6).

For operating temperatures above the allowable actuator temperature (refer to points 4.4 and 5.4) a water seal pot must be installed. The whole system, water seal pot, control line and actuator must be filled with liquid (by steam with water). The downstream pressure is converted over the actuator diaphragm in a force working in the disc closing direction.

The spring force is attained in the spindle over a pin and coupling and is opposed through the diaphragm force, therefore works in the disc open direction. When both forces are equal, the valve is balanced, and the downstream pressure is maintained constant.

When the downstream pressure is altered the disc either „opens“ or „closes“.

4.3 Diagram

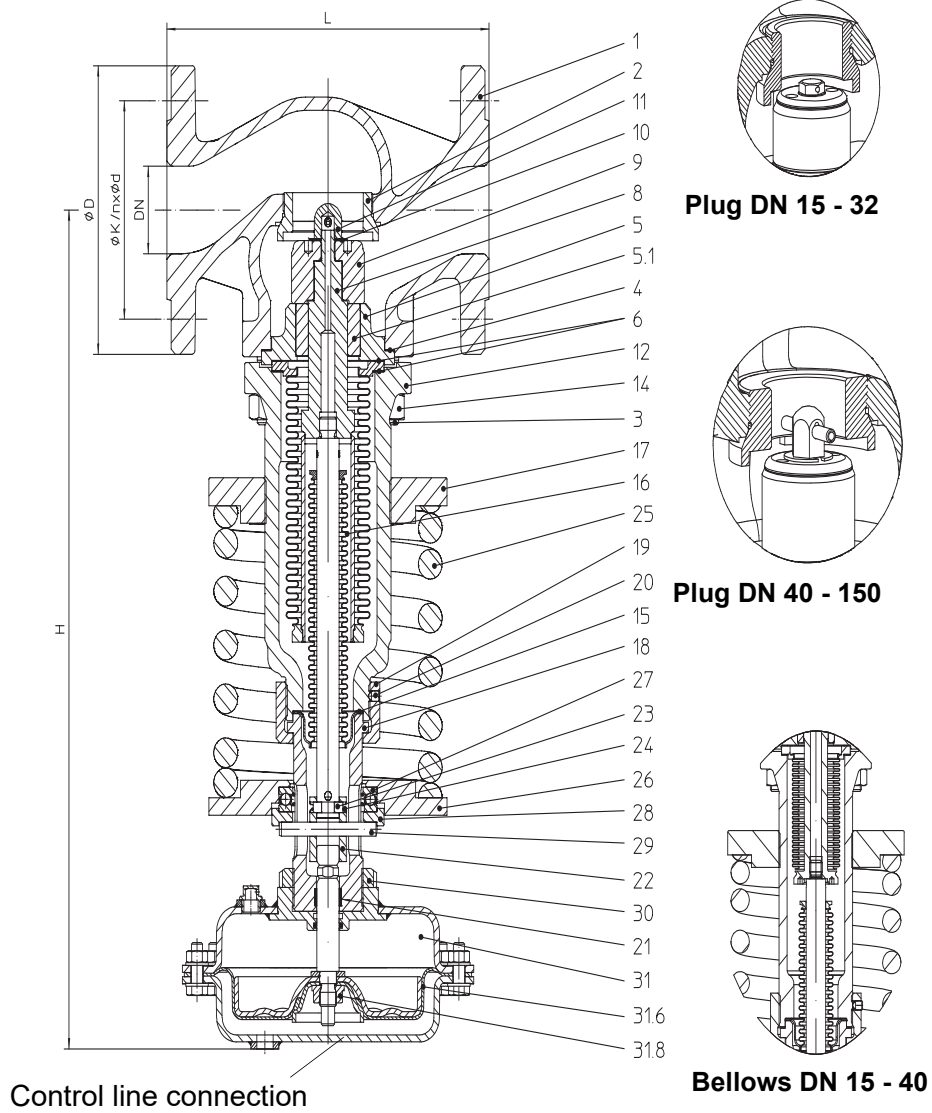

Fig. 1

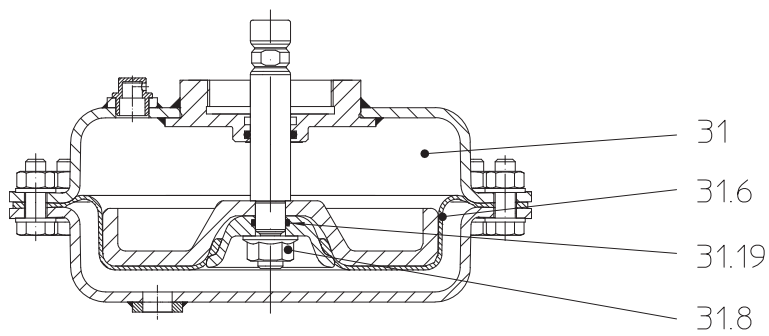

Fig. 2: Stainless steel - Actuator

4.3.1 Parts

Pos.	Designation
1	Body
2	Screwed seat
3	Stud
4	Gasket
5	Bush housing
5.1	Guide bush
6	Gasket
8	Balanced bellows unit
9	Plug unit
11	Head
12	Bonnet closed
14	Hexagon nut
15	Gasket
16	Sealing bellows unit
17	Adjusting plate
18	Head
19	Screw
20	Thread pin

Pos.	Designation
21	Guide bush
22	Guide coupling
23	Cylindrical balls
24	Securing wire
25	Spring
26	Spring plate
27	Axial bearing
28	Pressure plate
29	Pin
30	Lock nut
31	DMA-Pneumatic actuator
31.6	Rolling diaphragm
31.8	Collar nut with sealing ring
Stainless steel - Actuator:	
31.8	Hexagon nut with flanges
31.19	O-Ring

Refer to the data sheet for information about materials with designations and figure numbers.

4.4 Technical data - remarks

for

- **Principal dimensions**

- **Pressure-temperature-ratings, etc.** refer to datasheet.

Nominal diameter:	DN 15 - DN 150, 1" - 6"
Pressure class:	PN 16, PN 25, PN 40, ANSI 150, ANSI 300
Body material:	EN-JL1040, EN-JS1049, 1.0619+N, SA216WCB, 1.4581
Actuator size:	DMA 40, 80, 160, 250, 400 - NBR, EPDM
Downstream pressure:	acc. to downstream pressure table min. 0,2 bar, max. 16 bar
Temperature - valve:	acc. to pressure-temperature table refer to datasheet
Temperature - actuator:	max. 100°C (NBR-diaphragm) max. 130°C (EPDM-diaphragm)
Disc seal:	Metal, PTFE soft seal
Spindle tightness:	Stainless steel bellows

4.5 Marking

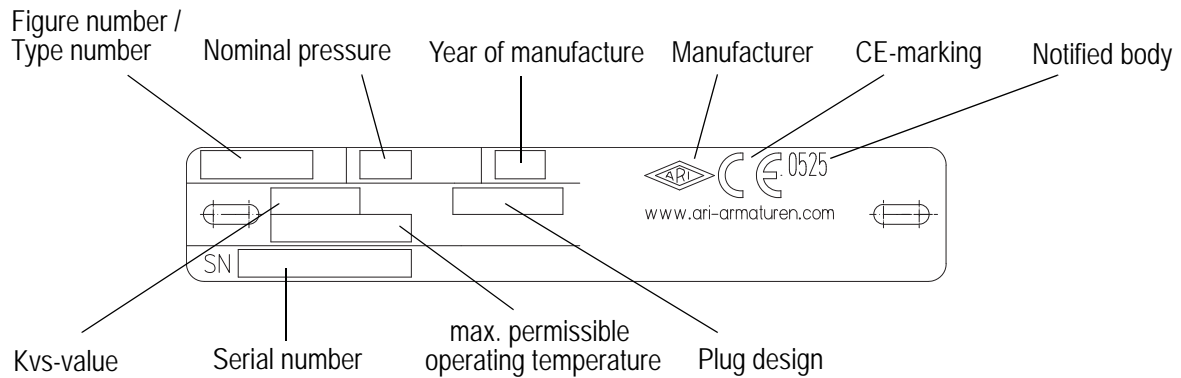

Fig. 3: Body

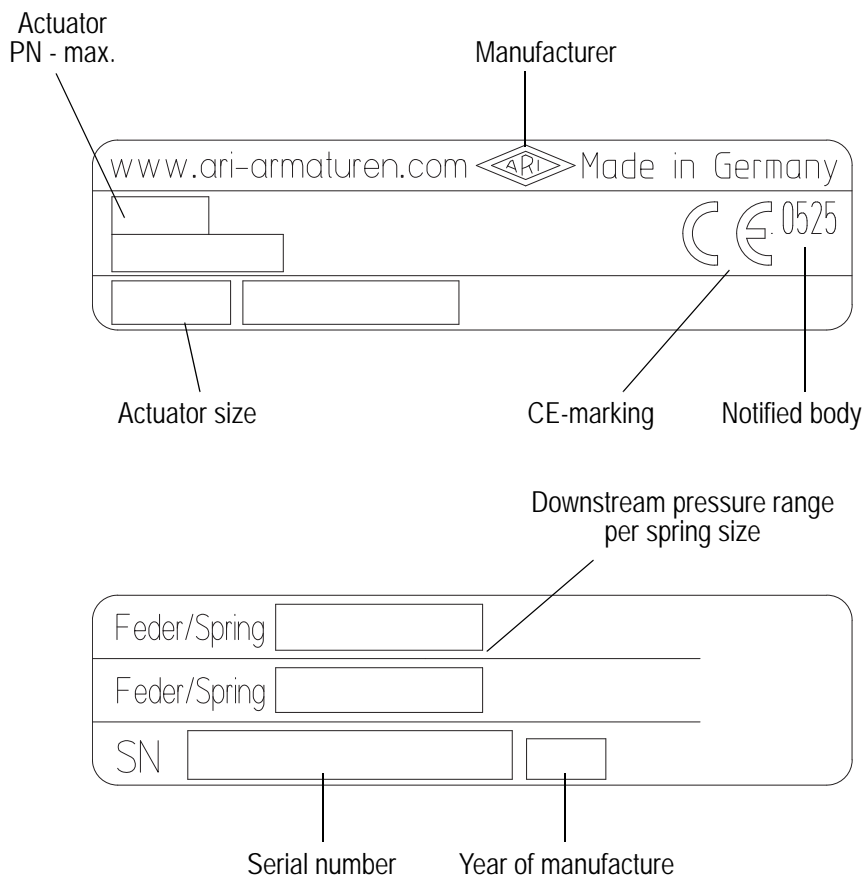

Fig. 4: Actuator

Address of manufacturer: refer to item 11.0 Warranty / Guarantee

According to the Pressure Equipment Directive table 6, annex II, valves without safety function are only allowed to bear the CE-marking DN32 onwards

Other marking is made on the outlet flange.
 e.g. BA/BQ or approvals such as LR, GL, etc.

4.5.1 Marking of special flanges

In case of deviations from the standard nominal pressure the valves are marked with an additional name plate on the flange.

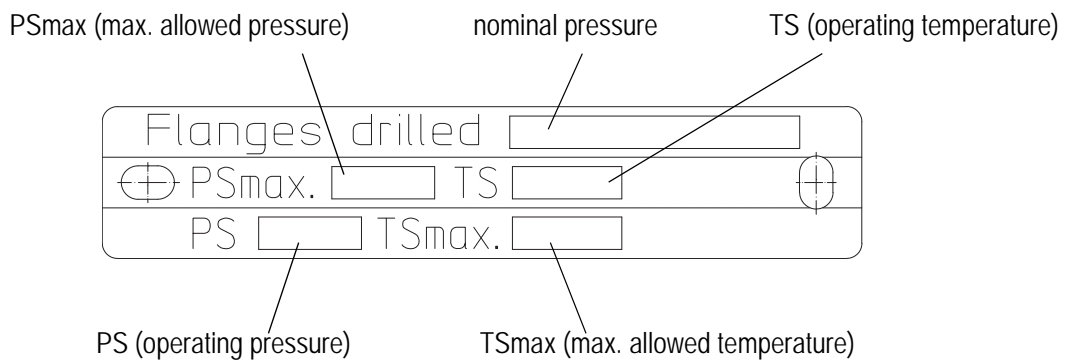

Fig. 5: Flange

The pairs of values of max. allowed pressure with its associated temperature and max. allowed temperature with its associated pressure are determined from the respective pressure-temperature diagram of material and nominal pressure.

5.0 Installation

5.1 General notes on installation

The following points should be taken into account besides the general principles governing installation work:



ATTENTION !

- Remove flange covers if present.
- The interior of valve and pipeline must be free from foreign particles.
- Note installation position with reference to flow, see mark on valve.
- Steam line systems should be designed to prevent water accumulation.
- Lay pipelines so that damaging transverse, bending and torsional forces are avoided.
- Protect valves from dirt during construction work.
- Connection flanges must mate exactly.
- Connecting bolts for pipe flanges should be mounted preferably from the counter flange side (hexagon nuts from the valve side).
At DN15-32: If valves should be mounted directly to valves, the upper flange connecting bolts should be preferably executed with studs and hexagon nuts on both sides.
- Valve mountings such as actuators, handwheels, hoods must not be used to take external forces, e.g. they are not designed for use as climbing aids, or as connecting points for lifting gear.
- Suitable materials handling and lifting equipment should be used.
See data sheet for weights.
- For operating temperatures above the allowable actuator temperatures (refer to point 4.4 and 6.0) a water seal pot must be installed full of water, for steam use (refer to point 5.4).
- When using a water seal pot the valve must be installed vertically downwards with the spring actuator below the pipe work. Otherwise the valve can be installed upright. The pressure reducing valve is only allowed to be installed in horizontal pipework.
- In case of a damaged diaphragm dangerous media (hot condensate, steam etc.) can escape out of the vent hole (screw plug), so connect with a pipe to a safe place.

- Planners / construction companies or operators are responsible for positioning and installing products.
- The valves are designed for application, not influenced from weather.
- For application outside or in adverse environments like corrosion-promoting conditions (sea water, chemical vapours, etc.), special constructions or protective measures are recommended.
- Before installing the pressure reducing valve rinse and clean the system otherwise the seat / disc will be damaged and the control hole will be blocked.
- Centre packings between the flanges.
- Keep the bonnet thread free from paint.

5.2 Requirements at the place of installation

The place of installation should be easily accessible and provide ample space for maintenance and removing the actuator. Install a stop valve upstream and downstream of the pressure reducing valve to enable repair and maintenance work, without emptying the system. A bypass line enables a continuous working by hand. Install manometers upstream and downstream to control the pressures.

Refer to a system sample under point 5.5 where all valves are shown. The piping before and after the pressure reducing valve must be dimensioned so that the max. flow speed is not exceeded, and the pressure reduction should be near to the users.

The nominal diameter of the pipes in front of and behind the pressure reducing valve must be chosen corresponding to max. allowable flow rates (liquids max. 5 m/s; saturated steam max. 25 m/s; steam and gases max. 50 m/s). With compressible media (i.e. steam, air) the downstream piping must be larger because when expanding the volume increase blocks the flow capacity. The rule 10 x DN is related to the larger downstream piping. When isolating of the piping, do not isolate the spring room, the actuator, the water seal pot and the control line.

5.3 Installation instructions concerning actuators

The pressure reducing valve is supplied with mounted actuator.



ATTENTION !

- It is not permitted to mantle / dismantle actuators with valves operating and service conditions (temperature and pressure) (refer to point 10.0)

To alter the pressure range the actuator and spring may have to be changed in the following sequence:

- Make the system pressureless.
- Remove control piping and empty the water seal pot.



ATTENTION !

- When disconnecting the control line piping, dangerous media can escape (hot condensate, steam)!

- Loosen lock nut (pos. 30).
- Unscrew actuator away from the valve.
- Relax spring by turning the spring plate (pos. 17).
- Remove sideways pin (pos. 29) and remove the pressure plate (pos. 26), bearing (pos. 27), spring plate (pos. 28) and spring downwards.
- Remount in the opposite way. The tightening torque for the lock nut is 50 Nm.



ATTENTION !

- The actuator must be screwed to the end position, then secure with the lock nut (pos. 30). Reconnect the control line. Do not turn the actuator for a better position.

- Putting the valve into operation (refer to point 6.0)

5.4 Control line, flow restrictor, water seal pot

The control line should at least have a diameter of 10 mm and can be fixed with the help of the supplied 90°-screw. The downstream connection for the control line should be 10 x DN, at least 1 m behind the pressure reducing valve, preferably on top or on the side of the pipe. With following distributor, the connection should be direct on the distributor.

! ATTENTION !

*Install water seal pot for temperature in excess of 100 °C
 Fill the water seal pot with water before starting up, e.g. with water vapour.
 Fill through the filler neck using the funnel attached.*

The water seal pot is mounted near the control line connection. The arrow on the shield must show downwards. You can fill the pot with the help of the supplied funnel (max. limit values PS 20 bar, TS -10°C to 350°C for downstream pressure).

Only when the pressure reducing valve shows unstable working, the supplied flow restrictor must be built in between actuator and control line.

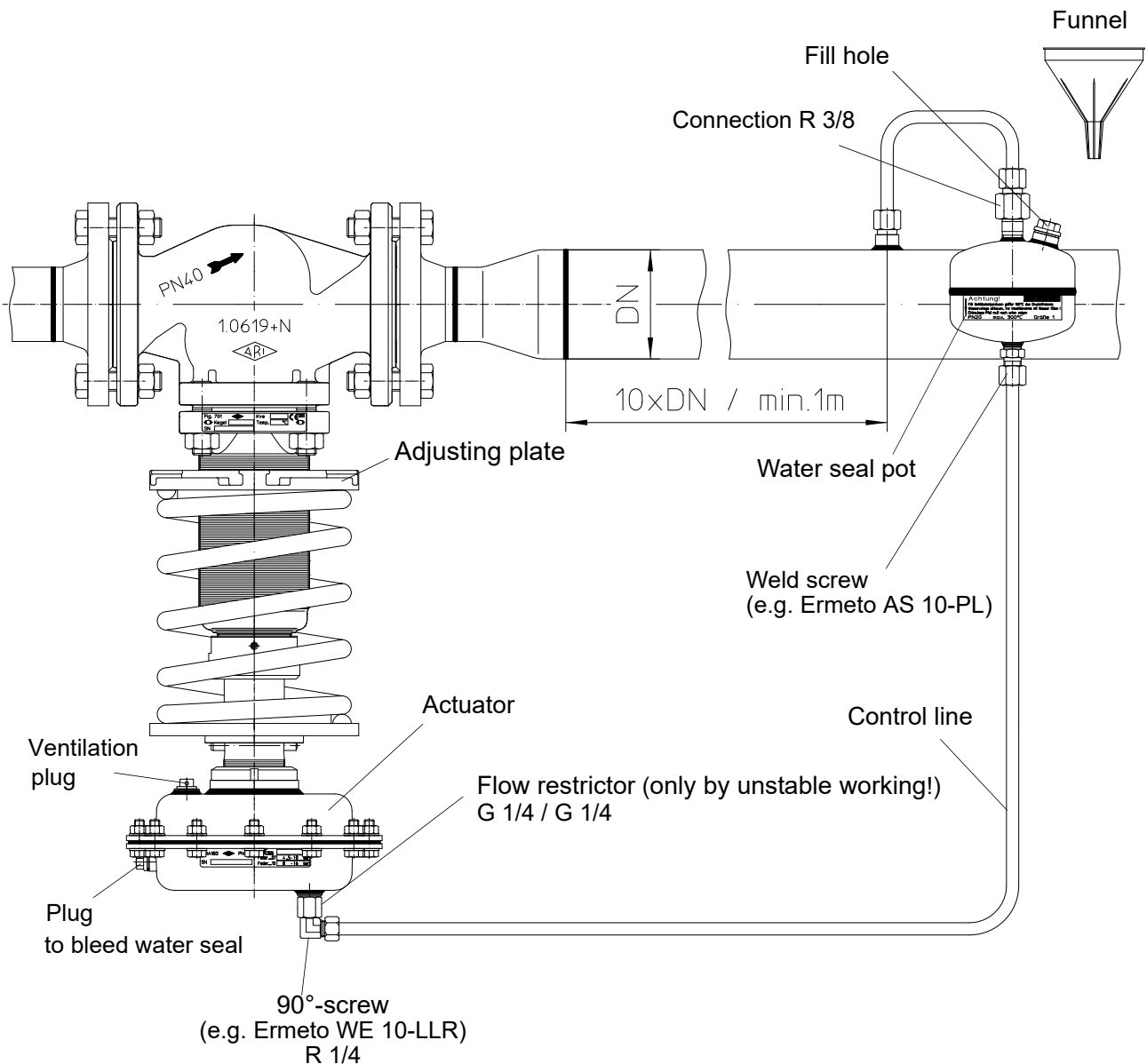

Fig. 6

5.5 System arrangement - pressure reducing station

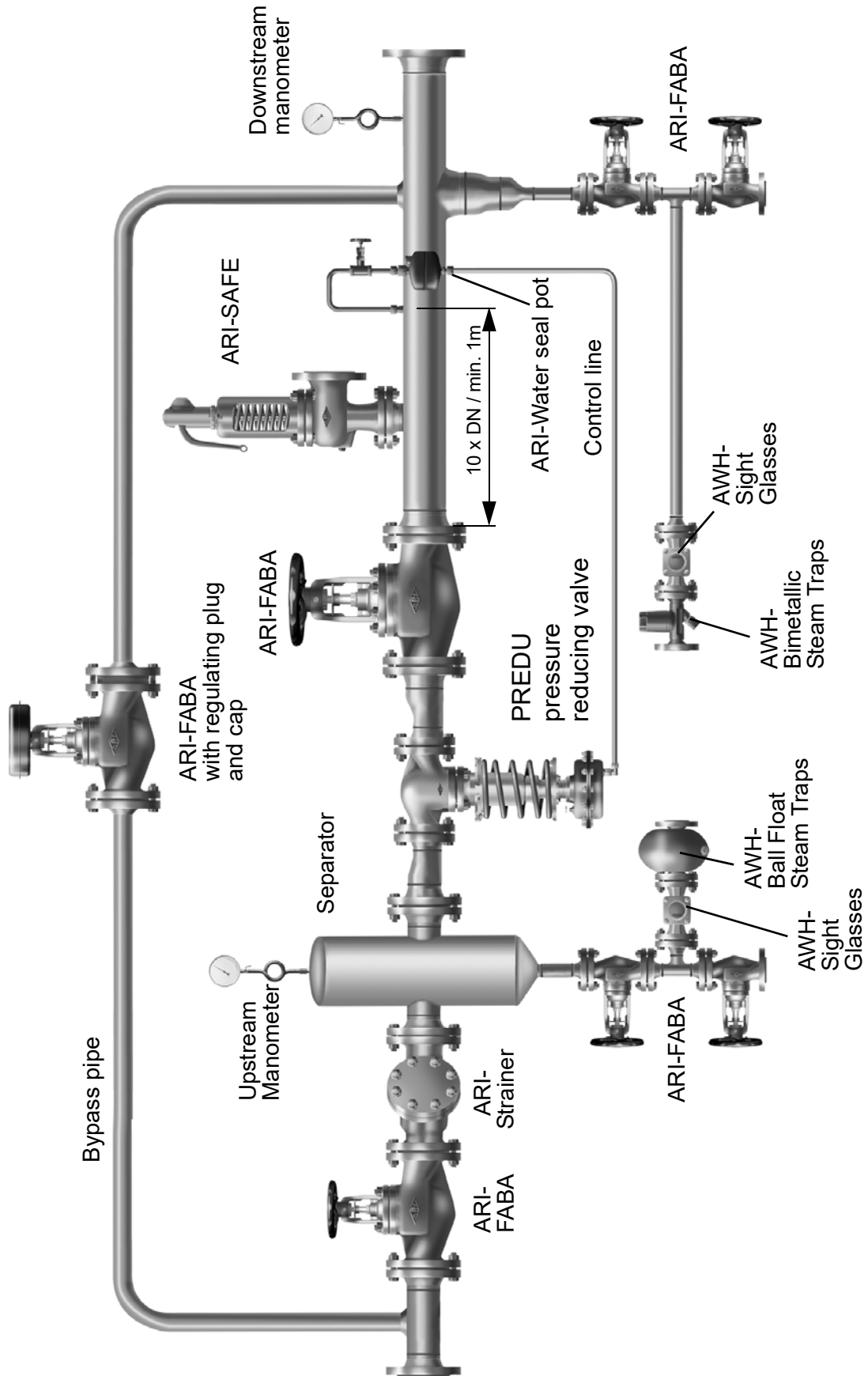

Fig. 7

5.6 Strainer



ATTENTION !

*Install a strainer before the pressure reducing valve, with the sieve sideways (with the medium steam) to avoid the collection of condensate.
The strainer must be cleaned from time to time.*

5.7 Safety valves



ATTENTION !

The system part behind the pressure reducing valve (downstream pressure side), the control line and actuator must be protected against excess pressure. The necessary safety valve must be dimensioned so that by max. possible upstream pressure, by fully open pressure reducing valve, the max. possible capacity must be blown off by the safety valve.

The set pressure must conform to the system part with the lowest nominal pressure.

An adequate distance must exist between the set downstream pressure and the safety valve set pressure.

If not secured that the bypass line works even more than the pressure reducing valve or can be open parallel to it, the capacity rating for the safety valve must include the extra capacity.

6.0 Putting the valve into operation



ATTENTION !

- *Before putting the valve into operation, check material, pressure, temperature and direction of flow.*
- *Regional safety instructions must be adhered to.*
- *Residues in piping and valves (dirt, weld beads, etc.) inevitably lead to leakage.*
- *Touching the valve when it is operating at high (> 50°C) or low (< 0°C) media temperatures can cause injury.*

Affix warning notice or protective insulation as appropriate!

- *The water seal pot is available for media temperatures over 100 °C (NBR-diaphragm) or 130 °C (EPDM-diaphragm).*

- *The water seal pot is completely filled (by steam with water) and the actuator is bled by the plug (refer to Fig. 6).*

Before putting a new plant into operation or restarting a plant after repairs or modification, always make sure that:

- *All works has been completed!*
- *The valve is in the correct position for its function.*
- *Safety devices have been attached.*

The operation is then as follows:

- If present open the valve in the control line.
- Open the valve behind the pressure reducing valve
- Now open the valve in front of the pressure reducing valve (medium must flow).
- Slacken spring by turning adjusting plate (pos. 17) to the left, pressure reducer closes.
- Now pre-tension spring by turning adjusting plate (pos. 17) to the right (size 19 spanner) until the desired downstream pressure is obtained (for possible downstream pressure see type plate on actuator), if downstream pressure is too high, slacken spring by turning adjusting plate (pos. 17) to the left.
- Now the pressure reducing valve is ready for use.



ATTENTION !

- *Squashing of finger between the spring coils and in the area of the pin in the head piece when the valve lift is moving.*
- *When in use high flow noise can occur.*

7.0 Care and maintenance

Maintenance and maintenance-intervals have to be defined by the operator according to the requirements.

8.0 Troubleshooting

In the event of malfunction or faulty operating performance check that the installation and adjustment work has been carried out and completed in accordance with these Operating Instructions.



ATTENTION !

- *It is essential that the safety regulations are observed when identifying faults.*

If malfunctions cannot be eliminated with the help of the following table "9.0 Troubleshooting table", the supplier or manufacturer should be consulted.

9.0 Troubleshooting table



ATTENTION !
*- read point 10.0 and 11.0 prior to dismantling and repair work !
 - read point 5.0 and 6.0 before restarting the plant !*

Fault	Possible cause	Corrective measures
No flow	Flange covers not removed.	Remove flange covers.
Little flow	Dirt sieve clogged.	Clean / replace sieve.
	Piping system clogged.	Check piping system.
	Kvs value of valve unsuitable.	Fit valve with higher Kvs value.
Downstream pressure rises quickly when the users are turned off	Seat / Disc leakage, very dirty	Change valve or, if necessary, seat/plug
	Control line or flow restrictor blocked	Clean control line or flow restrictor
	Diaphragm defect	Change diaphragm
	Thread plug blocked	Open hole in the vent plug screw
	Pressure balancing hole in the disc blocked	Open pressure balancing hole
	Balanced bellows defect	Renew balanced bellows
	Valve in the control line closed	Open valve in the control line
	Actuator not fitted proper	Loosen lock nut. Tighten actuator. Fix lock nut.
Flange broken.	Damage during transport.	Replace pressure reducing valve.
	Flange bolts not evenly tightened.	Replace pressure reducing valve.
	Transfer of unsafe forces such as bending or torsional forces.	Install free of tension.
Media comes out of the vent plug hole	Diaphragm leaking.	Change diaphragm.
Downstream pressure can not be adjusted in the full capacity range	Valve laid out to small.	New layout of valve.
	Valve setting is wrong.	Reset valve.
Valve doesn't regulate	Control line or flow restrictor blocked.	Clean control line or flow restrictor.
	Diaphragm defect.	Change diaphragm.
	Control line is connected to the vent plug hole.	Fix control line pipe to the control pipe connection.
Downstream pressure unstable	Flow restrictor not installed.	Install flow restrictor.
	The ratio of upstream to downstream pressure to high.	Reduction over two stages. Install pressure reducing valve in row.
Media exit out of the bonnet (at the spindle leakage)	Sealing bellows defect.	Change sealing bellows.
Downstream pressure can't be altered	Manometer defect.	Change manometer.
	Bonnet thread damaged.	Change bonnet.
	Valve closed in the control line.	Open valve in the control line.
Valve stem moves in jerks.	Valve plug slightly seized owing to solid dirt particles.	Clean internals, change plug and guide bush.

Fault	Possible cause	Corrective measures
Leakage too high when valve is closed.	Sealing surfaces of seat/plug eroded or worn.	Change valve or, if necessary, seat/plug.
	Sealing edge of seating damages or worn.	Change valve or, if necessary, seat/plug, fit strainer if necessary.
	Seat/plug leaking due to dirt.	Clean internals of valve, fit strainer if necessary. Change valve or, if necessary, seat/plug.
Unsafe rise in downstream pressure.	Safety valve not present in downstream pressure system.	Fit safety valve.
	Safety valve too small / wrong size.	Reset safety valve and replace if necessary.

10.0 Dismantling the valve or the top part



ATTENTION !

The following points must be observed:

- *Pressureless pipe system.*
- *Medium must be cool.*
- *Plant must be drained.*
- *Purge piping systems in case of caustic, inflammable, aggressive or toxic media.*

11.0 Warranty / Guarantee

The extent and period of warranty cover are specified in the "Standard Terms and Conditions of Albert Richter GmbH & Co. KG" valid at the time of delivery or, by way of departure, in the contract of sale itself.

We guarantee freedom of faults in compliance with state-of-the-art technology and the confirmed application.

No warranty claims can be made for any damage caused as the result of incorrect handling or disregard of operating and installation instructions, datasheets and relevant regulations.

This warranty also does not cover any damage which occurs during operation under conditions deviating from those laid down by specifications or other agreements.

Justified complaints will be eliminated by repair carried out by us or by a specialist appointed by us.

No claims will be accepted beyond the scope of this warranty. The right to replacement delivery is excluded.

The warranty shall not cover maintenance work, installation of external parts, design modifications or natural wear.

Any damage incurred during transport should not be reported to us but *rather* to the competent cargo-handling depot, the railway company or carrier company immediately or else claims for replacements from these companies will be invalidated.



ARI-Armaturen Albert Richter GmbH & Co. KG, D-33750 Schloß Holte-Stukenbrock
Telephone (+49 5207) 994-0 Telefax (+49 5207) 994-158 or 159
Internet: <https://www.ari-armaturen.com> E-mail: info.vertrieb@ari-armaturen.com

